

Архангельск (8182)63-90-72  
Астана (7172)727-132  
Астрахань (8512)99-46-04  
Барнаул (3852)73-04-60  
Белгород (4722)40-23-64  
Брянск (4832)59-03-52  
Владивосток (423)249-28-31  
Волгоград (844)278-03-48  
Вологда (8172)26-41-59  
Воронеж (473)204-51-73  
Екатеринбург (343)384-55-89  
Иваново (4932)77-34-06

Ижевск (3412)26-03-58  
Иркутск (395)279-98-46  
Казань (843)206-01-48  
Калининград (4012)72-03-81  
Калуга (4842)92-23-67  
Кемерово (3842)65-04-62  
Киров (8332)68-02-04  
Краснодар (861)203-40-90  
Красноярск (391)204-63-61  
Курск (4712)77-13-04  
Липецк (4742)52-20-81

Магнитогорск (3519)55-03-13  
Москва (495)268-04-70  
Мурманск (8152)59-64-93  
Набережные Челны (8552)20-53-41  
Нижний Новгород (831)429-08-12  
Новокузнецк (3843)20-46-81  
Новосибирск (383)227-86-73  
Омск (3812)21-46-40  
Орел (4862)44-53-42  
Оренбург (3532)37-68-04  
Пенза (8412)22-31-16

Пермь (342)205-81-47  
Ростов-на-Дону (863)308-18-15  
Рязань (4912)46-61-64  
Самара (846)206-03-16  
Санкт-Петербург (812)309-46-40  
Саратов (845)249-38-78  
Севастополь (8692)22-31-93  
Симферополь (3652)67-13-56  
Смоленск (4812)29-41-54  
Сочи (862)225-72-31  
Ставрополь (8652)20-65-13

Сургут (3462)77-98-35  
Тверь (4822)63-31-35  
Томск (3822)98-41-53  
Тула (4872)74-02-29  
Тюмень (3452)66-21-18  
Ульяновск (8422)24-23-59  
Уфа (347)229-48-12  
Хабаровск (4212)92-98-04  
Челябинск (351)202-03-61  
Череповец (8202)49-02-64  
Ярославль (4852)69-52-93

Киргизия (996)312-96-26-47

Россия (495)268-04-70

Казахстан (772)734-952-31

<https://lamborghini.nt-rt.ru/> || [hgc@nt-rt.ru](mailto:hgc@nt-rt.ru)

AZIENDA CERTIFICATA ISO 9001



**JEREZ ECO**

Basso NOx - Emisii reduce de NOx  
Niska emisja NOx - Low NOx



INSTRUCTIONS FOR USE, INSTALLATION AND MAINTENANCE

## GENERAL WARNINGS

- Read the warnings contained in this manual carefully.
- Once the unit is installed, describe its operation to the user and give them this manual. The manual is an integral part of the product and must be kept in a safe, accessible place for future reference.
- Installation and maintenance must be performed by a registered technician, in accordance with current standards and the manufacturer's instructions. Tampering with the sealed adjustment devices is prohibited.
- Improper installation or lack of appropriate maintenance may result in property damage or injury. The manufacturer will not be liable for damage caused by improper installation or use or, in any case, for failure to comply with the instructions.
- Before performing any cleaning or maintenance operations, unplug the unit from the mains power supply using the power switch or another cut-off device.
- In the event of a malfunction or improper operation, unplug the unit and have it repaired by qualified personnel. Only contact registered technicians. The unit must only be repaired, and its components replaced, by registered technicians using original replacement parts. Otherwise the safety of the unit may be compromised.
- This unit may only be used for the purpose for which it was expressly designed. Any other use must be considered inappropriate, and therefore hazardous.
- The packing materials are a potential source of danger, and must be kept out of reach of children.
- The unit can be used by children aged at least 8 years and by persons with reduced physical, sensory or mental capabilities, or lacking experience or the necessary knowledge, only if under supervision or they have received instructions on its safe use and the related risks. Children must not play with the unit. Cleaning and maintenance intended to be done by the user can be carried out by children aged at least 8 years only if under supervision..
- Dispose of the unit and its accessories in accordance with current standards.
- The images contained in this manual are a simplified representation of the

product. Such representations may include slight, insignificant differences with respect to the product supplied.

• APPLIANCE INTENDED FOR DOMESTIC USE; NOT VALID FOR INDUSTRIAL USE.



**This symbol means “Caution,” and is displayed next to safety warnings. Carefully observe such warnings to avoid hazardous situations, property damage, and injury to people and animals.**



Important information involving no risk of injury or property damage is indicated by this symbol.



The CE marking certifies that products meet the fundamental requirements of the applicable European directives. The declaration of conformity can be requested from the manufacturer.

The unit is suitable for operation in a partially protected with temperatures from -5°C to +60°C.

<b>1 USER'S MANUAL</b> .....	<b>53</b>
1.1 Introduction .....	53
1.2 Control panel .....	53
1.3 Turning the heater on and off.....	53
1.4 Settings.....	53
1.5 Faults .....	54
<b>2 INSTALLATION MANUAL</b> .....	<b>54</b>
2.1 General information .....	54
2.2 Location .....	54
2.3 Assembling the heater .....	55
2.4 Hydraulic connections.....	56
2.5 Gas connection.....	57
2.6 Air and flue gas ducts .....	57

<b>3 SERVICE AND MAINTENANCE</b> .....	<b>58</b>
3.1 ADJUSTMENTS.....	58
3.2 COMMISSIONING .....	59
3.3 MAINTENANCE.....	59
3.4 REPLACING THE BATTERIES .....	60
<b>4 TECHNICAL DATA AND CHARACTERISTICS</b> ....	<b>61</b>
4.1 Dimensions and connections .....	61
4.2 Overview and main components .....	62
4.3 Hydraulic circuit .....	63
4.4 Technical data table .....	64
4.5 Wiring diagram.....	66

## 1 USER'S MANUAL

### 1.1 Introduction

The new **JEREZ ECO** is a high-performance, low-emission heater for domestic hot water production, powered by **natural gas** or **LPG** and equipped with a compact, **WATER-COOLED**, battery-powered burner with electronic ignition, designed for indoor installation.

### 1.2 Control panel

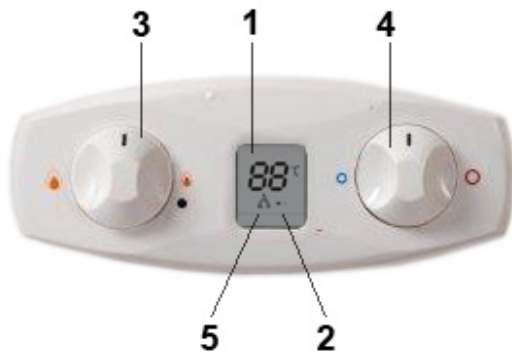

fig. 1 - Control panel

- |   |   |                           |
|---|---|---------------------------|
| 1 DHW temperature indication at the outlet from the boiler  | the battery is dead and must be replaced. | 3 Burner power adjustment |
| 2 Battery charge indication. Fixed symbol: Very low battery; change as soon as possible. When flashing, |   | 4 Temperature adjustment  |
|   |   | 5 Burner on indication    |

### 1.3 Turning the heater on and off



**When the unit is working, the temperature near the peephole may be high. Avoid contact as there may be risk of burns.**

Preliminary checks and operations

- 1 Make sure the hot water taps are closed.
- 2 Open the gas supply cock to the heater, located at the gas connection to the unit.
- 3 Check that the 1.5 V batteries are properly installed with the correct polarity (+/-). To replace the batteries, see (3.4 Replacing the batteries).
- 4 Also verify that the batteries are sufficiently charged for heater operation.

### 1.3.1 Turning the unit on

Turn the knob to the required water heating level. The unit will begin operating every time hot water is drawn.



fig. 2 - Turning the unit on

### 1.3.2 Turning the unit off

The burner goes off automatically when hot water is no longer demanded.

To use the unit again, no action is required.

To completely shut off the unit, place the knob in the ( ) position.



fig. 3 - Turning the unit off

If the water heater will not be used for an extended period of time, close the gas cock supplying the unit.



**If the unit will be inactive for an extended period of time during the winter, all water should be removed to avoid ice damage.**

### 1.4 Settings

#### 1.4.1 Setting the burner power manually

Use the knob (3 fig. 1) to select the heater power. You may choose between the minimum, maximum, and intermediate positions, depending on the required heating power.

If the knob is turned counterclockwise, the unit will operate at maximum power. If the temperature is too high, for example in the summer, or if you need a reduced flow of not very hot water, turn the knob clockwise. This reduces the power, and therefore the gas consumption. In the ● position, the unit is turned off.

### 1.4.2 Setting the temperature

Turn the water temperature selector clockwise to increase the temperature, or counterclockwise to decrease it.



fig. 4 - Setting the temperature

### 1.5 Faults

Once the adjustments described above have been made, the heater is ready to operate automatically. When a hot water tap is opened, an intermittent discharge is generated on the ignition electrode to light the burner.

All electronic models have an ionization electrode built into the burner to monitor flame presence. If a malfunction or lack of gas causes the heater to turn off, close the hot water tap.

It is then necessary to eliminate the fault or obstacle preventing the gas from reaching the heater, e.g., inadvertent closing of the gas cock, empty gas cylinder, etc.

To reactivate the heater, close and open the hot water tap.

If no hot water is produced after eliminating the cause and opening the hot water tap, repeat the process.

If the problem persists, call the technical support center.

Table 1 - Faults

E3	The burner does not ignite	Absence of gas	Check the flow of gas to the heater, and make sure the pipes have been purged.
		Failure of the ignition/detection electrode	Check the electrode cable, and make sure it's properly connected and free of deposits.
		Defective gas valve	Check and/or change the gas valve.

EE	Activation of the over-temperature protection	Damaged or badly positioned heating sensor	Check that the heating sensor is properly installed and operating and/or change it.
	Activation of the flue gas thermostat (after this operation, the unit is reset by turning on the tap, and the thermostat cools off).	Flue gas thermostat contact open	Check the thermostat.
Cables disconnected		Check the connections.	
Thermostat obstructed or incorrectly sized		Check the thermostat.	
--		Probe disconnected	Check the connection or change the probe.

## 2 INSTALLATION MANUAL

### 2.1 General information



**The heater may only be installed by an authorized technician, in accordance with all instructions contained in this manual, standard UNE 26, and local installation and exhaust regulations.**

### 2.2 Location

Make sure the water heater chosen is the most suitable:

- To adequately meet the system's hot water requirements.
- For the gas to be used (see water heater dataplate).
- For the water supply pressure, necessary for operation (see table of characteristics).

**Make sure the room where the unit is installed meets all the requirements of the Current Regulations. In particular, this unit is an "open chamber" type and must only be installed and operate in permanently ventilated places. An insufficient supply of combustion air will compromise normal operation and the evacuation of fumes. Also, the fumes forming under these conditions are extremely harmful to health if**

dispersed in the domestic environment. **OTHERWISE THERE MAY BE RISK OF SUFFOCATION AND INTOXICATION OR EXPLOSIONS AND FIRE..** Therefore the place of installation must be free of dust, flammable materials or objects or corrosive gases.

Position the water heater as close as possible to the hot water taps, near the sink, but **NEVER** above a cooktop. It must also be situated as close as possible to the flue or the start of the flue gas exhaust pipe.

 **If the unit is installed inside a cabinet or joined laterally to other elements, space must be allowed for removing the casing and performing normal maintenance activities.**

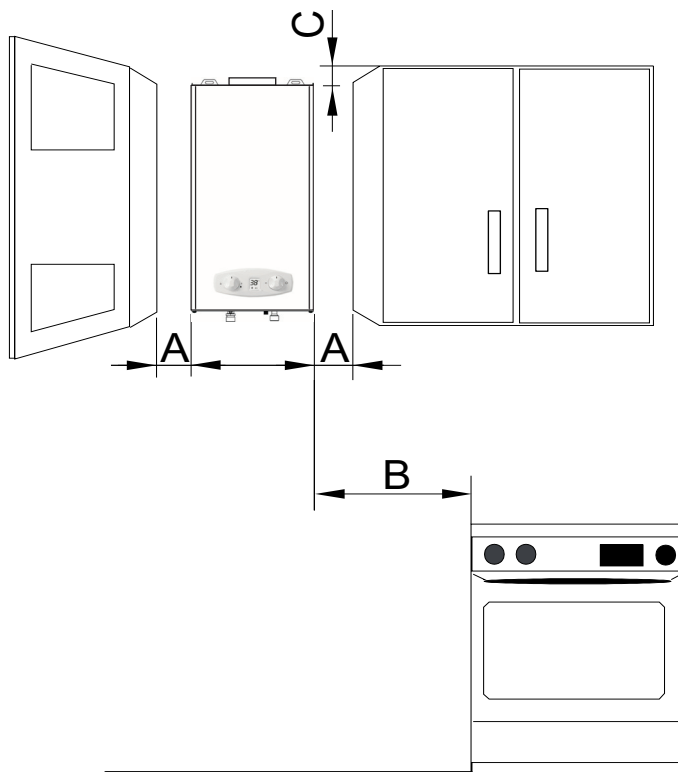

fig. 5 - Minimum distances

A	<b>On each side</b>	>2cm
B	-	>50cm
C	<b>In front</b>	>2cm

## 2.3 Assembling the heater



**Before assembling the heater, make sure the water and gas connections are properly secured, identified, and positioned. See the dimensions and connections in section 4.2.**

- Fix the plugs and hooks on the wall, in a central position vertical to the appliance, as shown in the figure below.
- Mark the position of the bottom screws
- Hang the water heater on the plugs+hooks and tighten the screws for fixing the unit to the wall.
- Connect the hot and cold water flexible tubes, remembering to check their tightness. To avoid circulation problems, do not remove the cold water inlet filter.

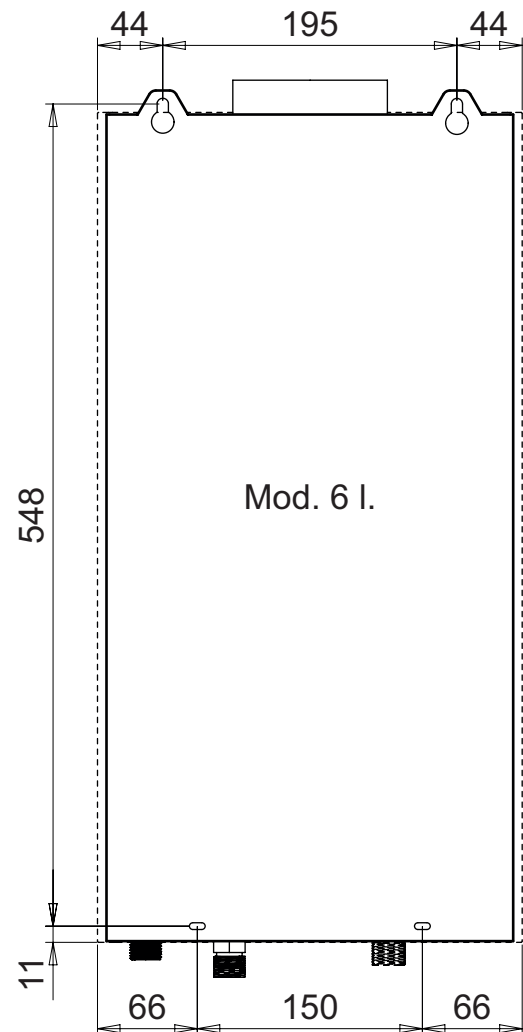

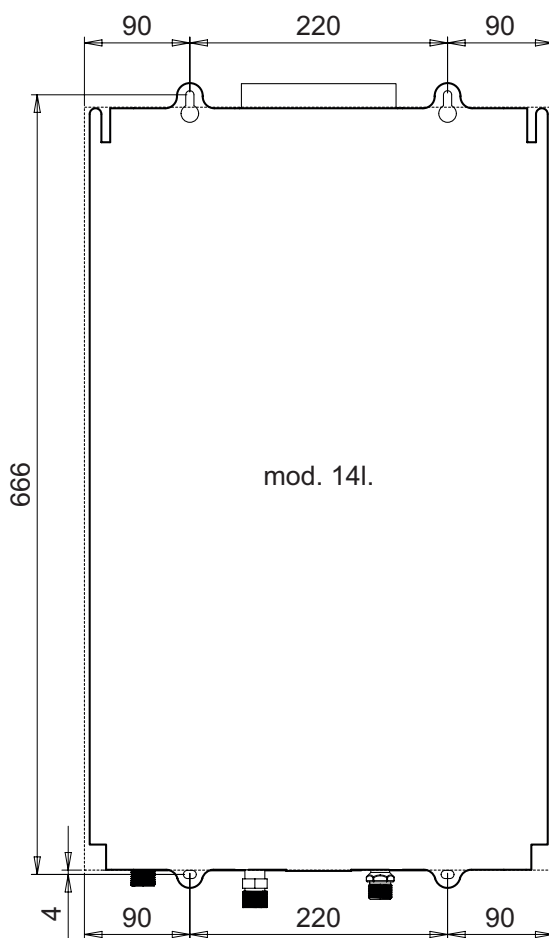
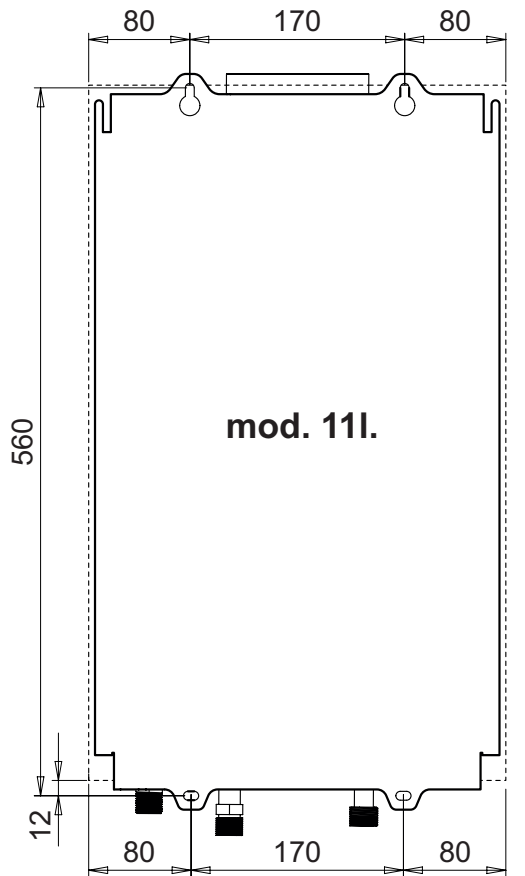

fig. 6 - Assembly template

- Remove the unit from the packaging.
- Verify all documents.
- Remove the plugs from the water and gas connections (see fig. 8).
- On the rating label, check the destination country reference and the type of gas for which the unit is supplied.

**Lamborghini**  
CALORECLIMA

**JEREZ ECO 11**

Appr. nr. CA.1M      Ser.n. 1905G80032

**B11BS**

I12H3B/P (AT-CH)	EE-TR-RO-HR
SI-GR-SK-CZ-LT	I12H3+ (ES-PT-GB-IE)
I12E3B/P (DE-LU)	I12HS3B/P (HU)
I3P (CY-PL-MT)	I2H (LV)
I12ELW3B/P (PL)	I12HM3+ (IT)

<b>2HM-2E-2H-2HS-2ELW</b>	<b>G20/G230</b>	<b>20 mbar</b>
---------------------------	-----------------	----------------

	max	-	min	
Qn (Hi)	21.1	-	8.1	kW
Pn 80° - 60°	18.9	-	7.0	kW
Pn 50° - 30°		-		kW

PMS	bar	PMW	10.0	bar
tmax	°C	D	11	l/min

NOx 6 (< 56 mg/kWh)      H<sub>2</sub>O

**CE** 0085 / 19



6 938771 373440

1905G80032

3V =  W      IPX4D

Suitable for operation in a partially protected place  
MADE IN CHINA

fig. 7 - Rating label

## 2.4 Hydraulic connections



**Never support the water heater by the water/gas connections. Make the connections in accordance with the dimensions and connections shown in section 4.1.**

There are labels on the unit identifying the 1/2" water inlet pipe (white) and the 3/4" gas inlet pipe (yellow).

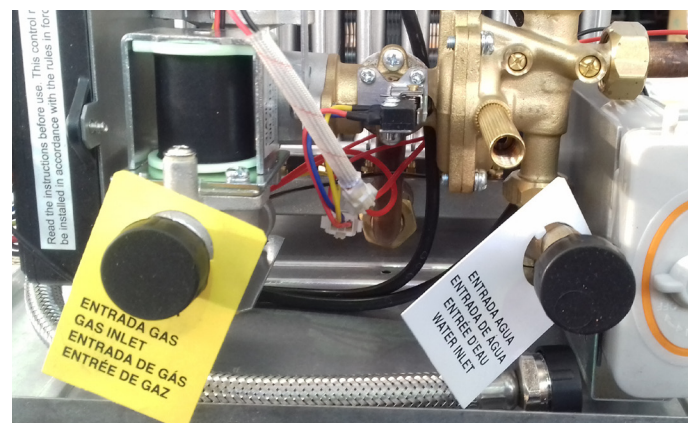

fig. 8 - Connection cards

**☞** *If the water hardness is over 25°Fr (1°F=10ppm CaCO<sub>3</sub>), the water must be treated to avoid possible deposits on the unit.*

## 2.4.1 Water flow rate adjustment

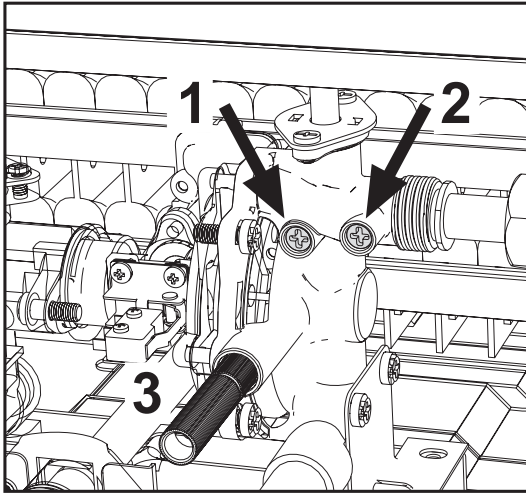

fig. 9 - Water flow adjustment screws

### Legend

- 1 - Minimum water flow regulation screw.
- 2 - Maximum water flow adjustment screw.
- 3 - Safety valve drain water.

## 2.5 Gas connection



**Before making the connection, check that the unit has been prepared to operate with the right type of fuel, and carefully clean the gas pipes to remove any residue that might hinder correct operation. Make this connection in accordance with the dimensions and connections in section 4.1.**

- 1 Connect the corresponding gas inlet (see section 4.2) in accordance with current regulations in the country where the heater is being installed.
- 2 Connect using a **rigid metal pipe (connection to a gas supply network) or a flexible, continuous stainless steel pipe (LPG installation)**, adding a shut-off valve between the installation and the unit **(AS CLOSE TO THE UNIT AS POSSIBLE)**.
- 3 Once the connection to the gas network is complete, check that all gas connections are tight. For this purpose, a tightness test must be performed. To avoid

damage to the unit due to excess pressure, leave the gas inlet valve closed.

- 4 Check that the supplied pressure and gas delivery values are those indicated for the unit's consumption. See the technical data table (section 4.5).



**In installations with an approved flexible pipe for LPG, pay special attention to the following.**

- The pipe must comply with applicable regulations.
- Avoid areas with heat emissions.
- Prevent the pipe from bending or being pinched shut.
- The connections on both sides (gas valve and other components) must comply with the regulations of the country where the heater is installed.

## 2.6 Air and flue gas ducts

The diameter of the pipe connecting to the flue must not be smaller than that of the pipe connecting to the draft hood. After the draft hood, there must be a vertical segment at least half a meter long. The dimensions and installation of the flues and the tube connecting to them must comply with current standards.

### 2.6.1 FUME EXHAUST SAFETY DEVICE (fume thermostat)

- The water heater's safety device ensures the correct exhaust of flue gases; **THEREFORE DO NOT DEACTIVATE IT OR CARRY OUT ANY OPERATION ON IT.**
- If the safety device cuts in when the water heater is started, check the flue gas outlet, checking the exhaust with a cold mirror or with any suitable and approved measuring device.
- In case of a fault, only use original replacements, otherwise the safety device may not work properly.
- Fume thermostat replacement must be carried out by qualified technicians, proceeding as follows:
  - Remove the faulty fume thermostat by undoing the 2 fixing screws.
  - Install a new original thermostat.
  - Fix the fume thermostat in its place without over-tightening the screws.
  - Check its correct operation.





**Remember to make an air inlet opening in the room where the water heater is installed (as required by the current regulations).**

**If the above instructions are not observed there may be risk of suffocation or poisoning due to gas or fumes escaping.**

### 3 SERVICE AND MAINTENANCE

All of the adjustments, commissioning operations and periodic checks described below must be performed by an authorized technician in compliance with current regulations. **FERROLI** declines all liability for property damage or injuries caused by unauthorized persons tampering with the unit.

#### 3.1 ADJUSTMENTS

##### 3.1.1 Gas conversion



**Conversion of the unit to a type of gas other than the factory setting must be performed by an authorized technician, using original components and in compliance with current regulations in the country where the unit will be used.**

The unit can operate with methane gas, LPG or Propane-Air. It is factory-set for one of the two types of gas, as indicated on the packaging and technical data plate. To operate the unit with another type of gas, a conversion kit must be used.

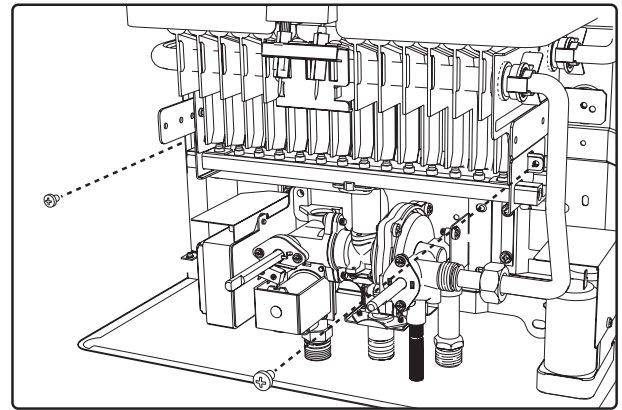

fig. 10 -

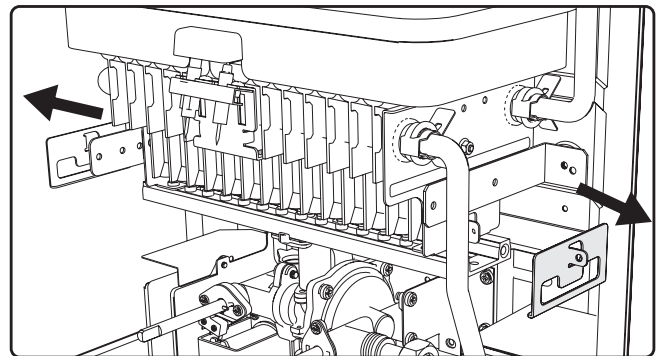

fig. 11 -

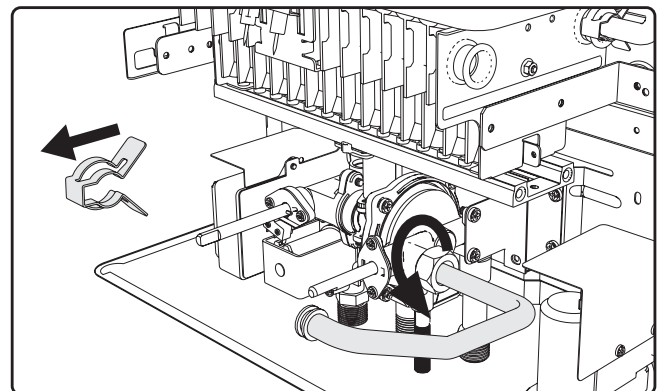

fig. 12 -

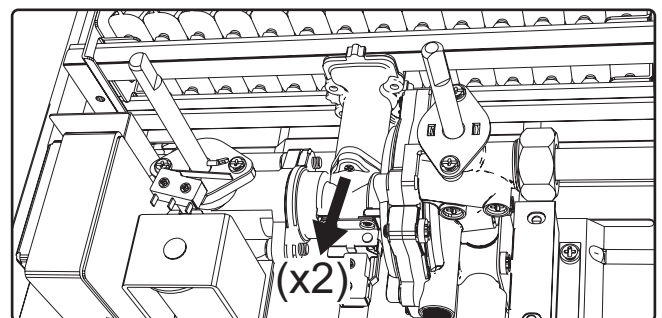

fig. 13 -

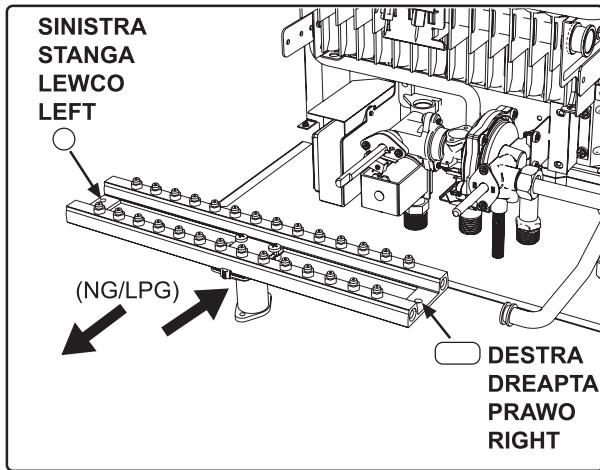

fig. 14 -

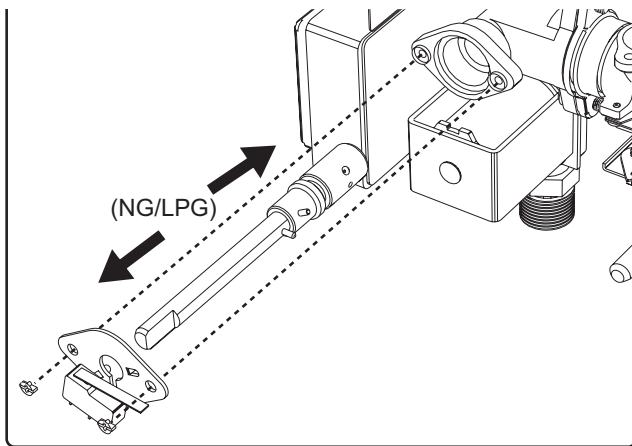

fig. 15 -

## 3.2 COMMISSIONING



**Commissioning of the heater must be performed by a trained, specialized technician. Checks that must be performed during the first ignition, after maintenance operations that require unplugging the unit, and after any operations on the unit's safety devices or components.**

### 3.2.1 Before igniting the heater

- Carefully verify the tightness of the gas installation using a soap and water solution to check for leaks in the connections.
- Fill the hydraulic system and make sure no air is present in the unit or system.
- Check that there are no water leaks in the system or

unit.

- Make sure the grounding and connection to the electrical network are adequate.
- Check that the gas pressure is correct.
- Make sure there are no flammable liquids or materials near the heater.
- To avoid damaging the connections, do not place the heater on the floor with the connections facing down.



**If the above instructions are not observed there may be risk of suffocation or poisoning due to gas or fumes escaping; danger of fire or explosion. Also, there may be risk of flooding the room.**

### 3.2.2 Checks during operation

- Light the unit.
- Make sure the fuel and water systems are tight.
- Check the efficiency of the air and flue gas ducts while the heater is operating.
- Make sure the gas valve modulates correctly.
- Verify that the heater ignites easily. Turn it on and off several times to make sure.
- Check that the fuel consumption is as indicated.

## 3.3 MAINTENANCE

### 3.3.1 Periodic checks

In order for the unit to operate correctly, an authorized technician must perform an annual inspection, checking that:

- The control and safety devices (gas valve, etc.) operate correctly.
- The exhaust vent is perfectly efficient.
- The air and flue gas ducts and terminal are free of obstacles and leaks.
- The burner and exchanger are free of dirt and deposits. Do not use chemicals or steel brushes to clean them.
- The electrode is free of deposits and properly positioned.

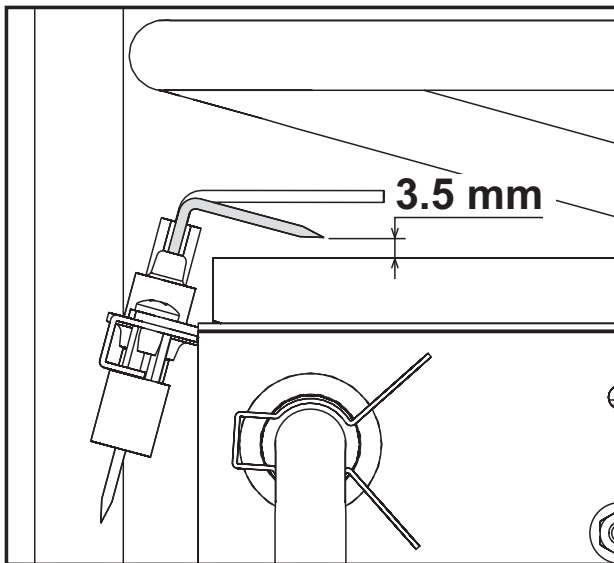

fig. 16 - Electrode position

- The gas and water systems are perfectly tight.
- The gas delivery and operating pressure values are as indicated on the tables.

A soft, damp cloth may be used to clean the casing and exterior parts of the heater, using soapy water if necessary. Do not use abrasive detergents or solvents.

### 3.3.2 Opening the casing

To open the casing:

- 1 Unscrew the A screws.
- 2 Rotate the casing.
- 3 Lift the casing.

 **Before performing any operations inside the heater, close the gas cock.**

### 3.4 REPLACING THE BATTERIES

To change the batteries, proceed as described in fig. 18.

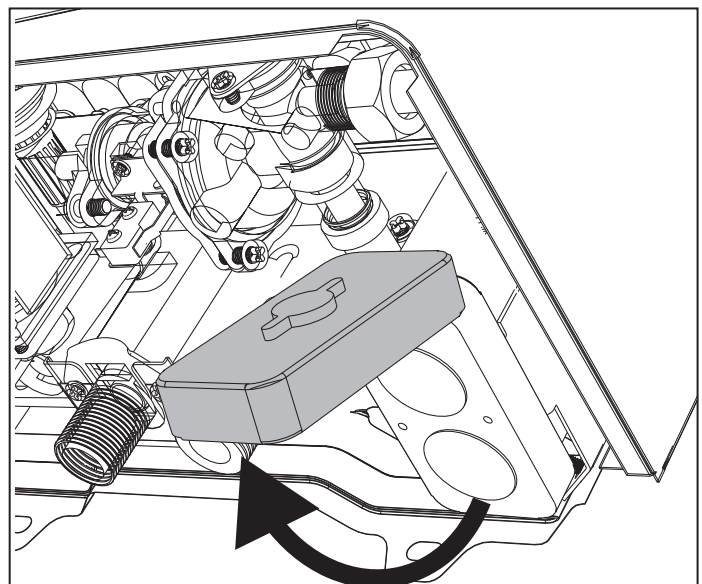
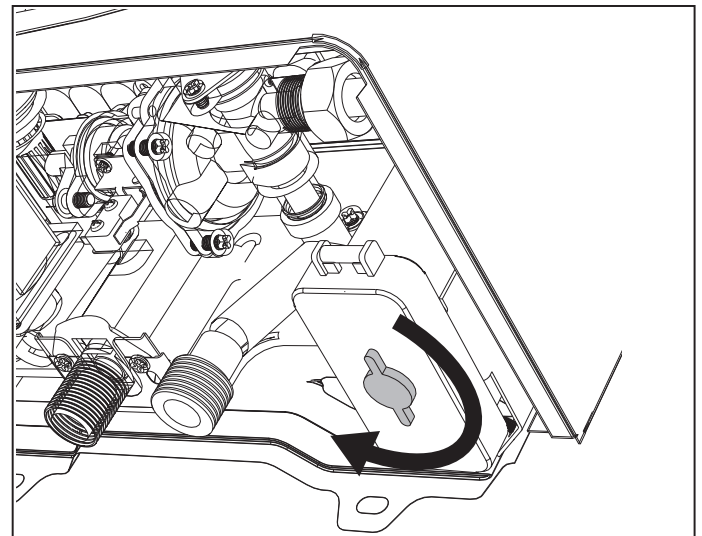

fig. 18 - Opening the battery box

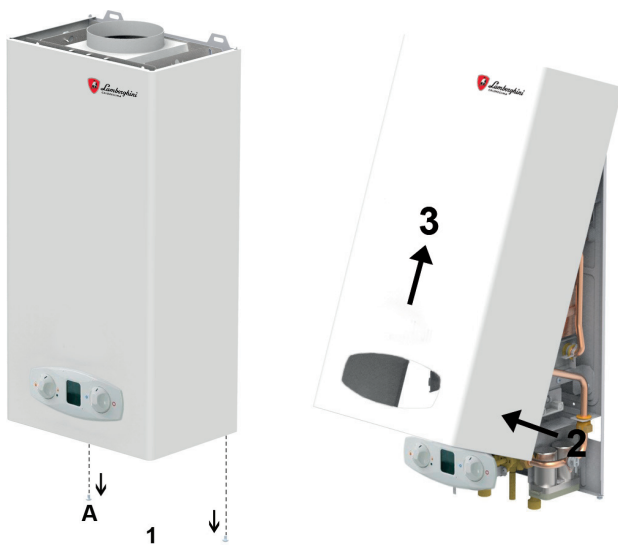

fig. 17 - Opening the casing

## 4 TECHNICAL DATA AND CHARACTERISTICS

### 4.1 Dimensions and connections

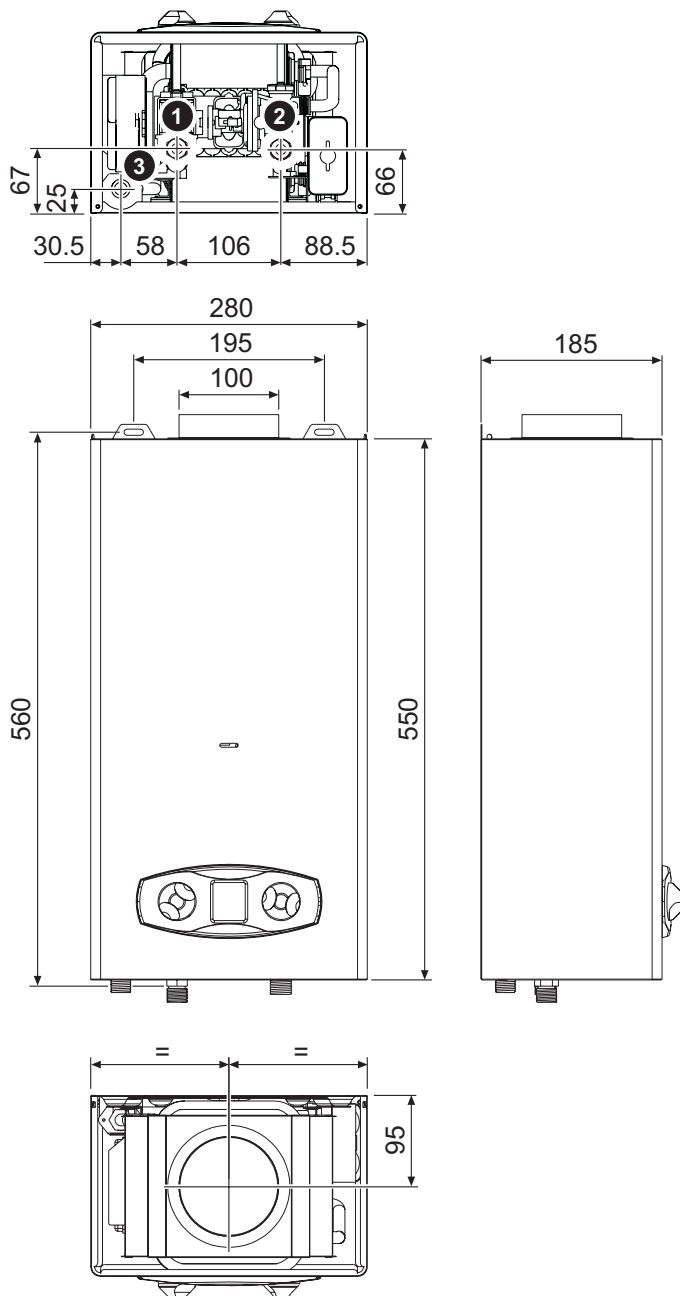

fig. 19 - Dimensions and connections JEREZ ECO 6

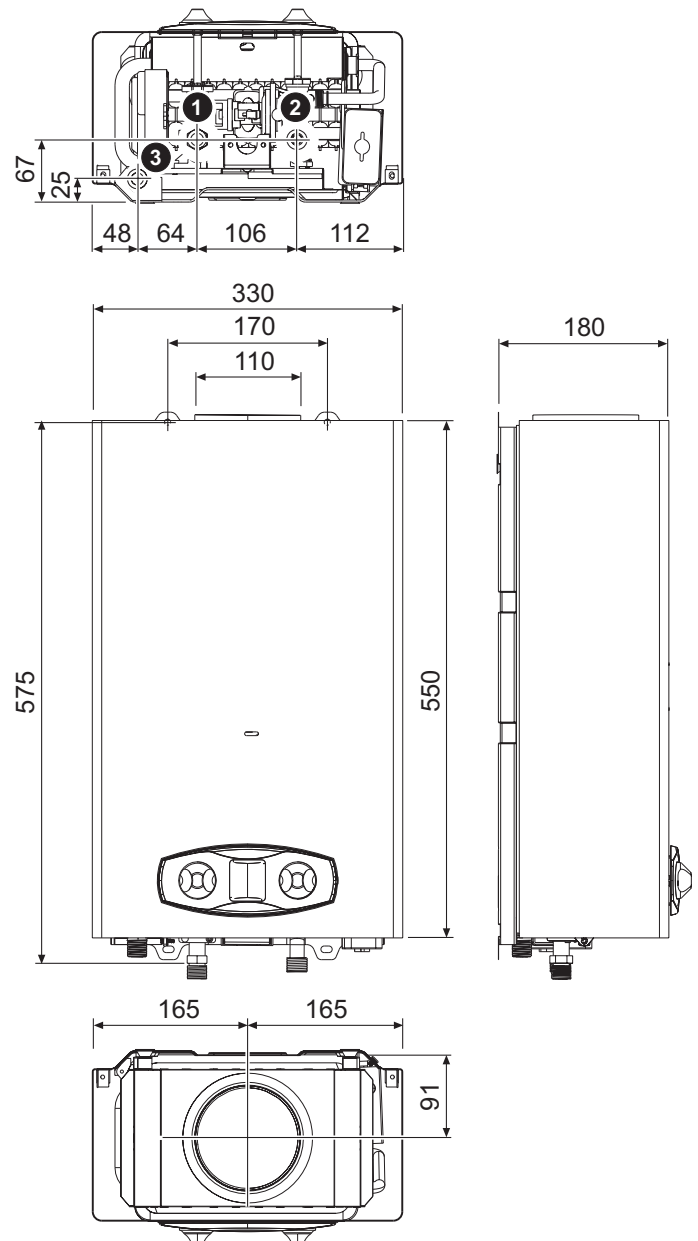

fig. 20 - Dimensions and connections JEREZ ECO 11

**4.2 Overview and main components**

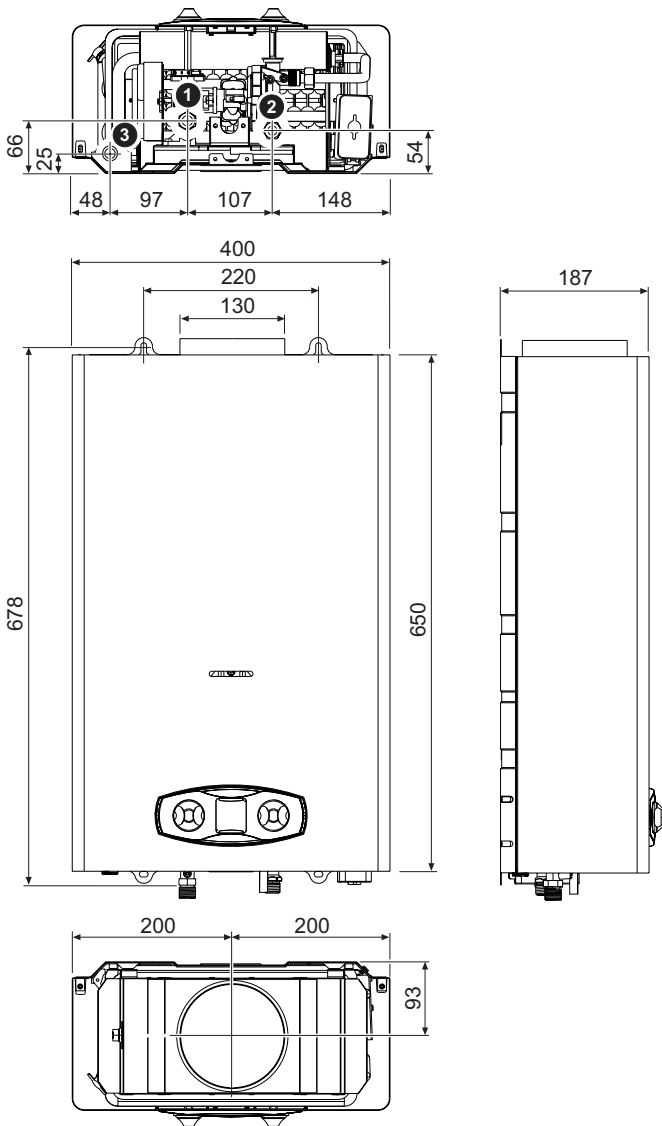

fig. 21 - Dimensions and connections JEREZ ECO 14

- 1 1/2" gas inlet
- 2 1/2" cold water inlet
- 3 1/2" domestic hot water outlet

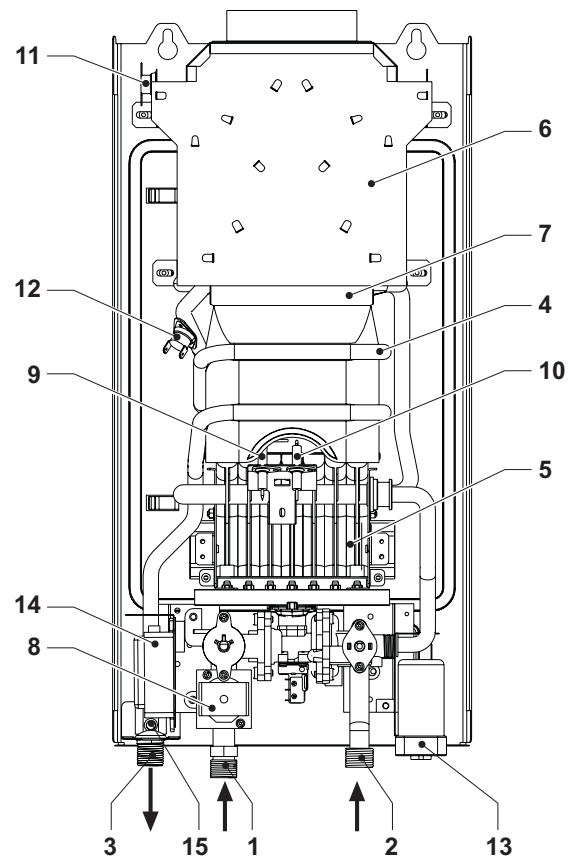

fig. 22 - Overview JEREZ ECO 6

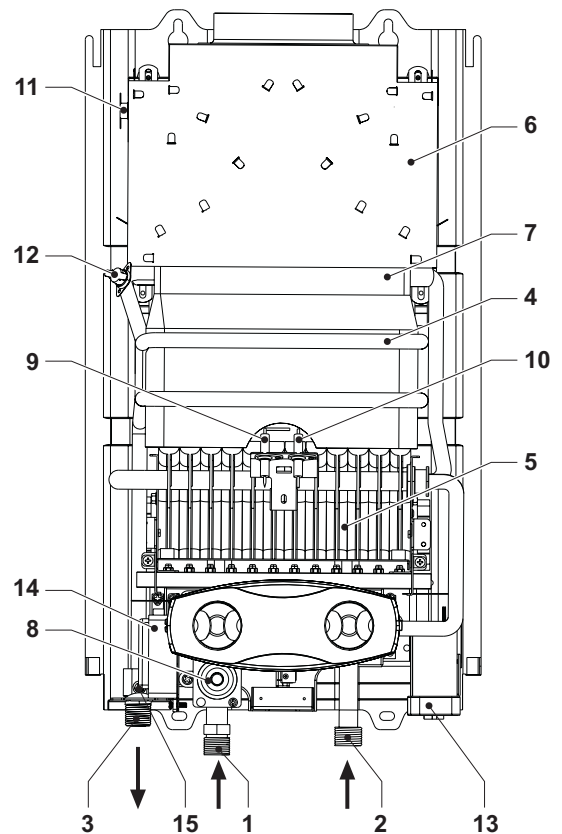

fig. 23 - Overview JEREZ ECO 11

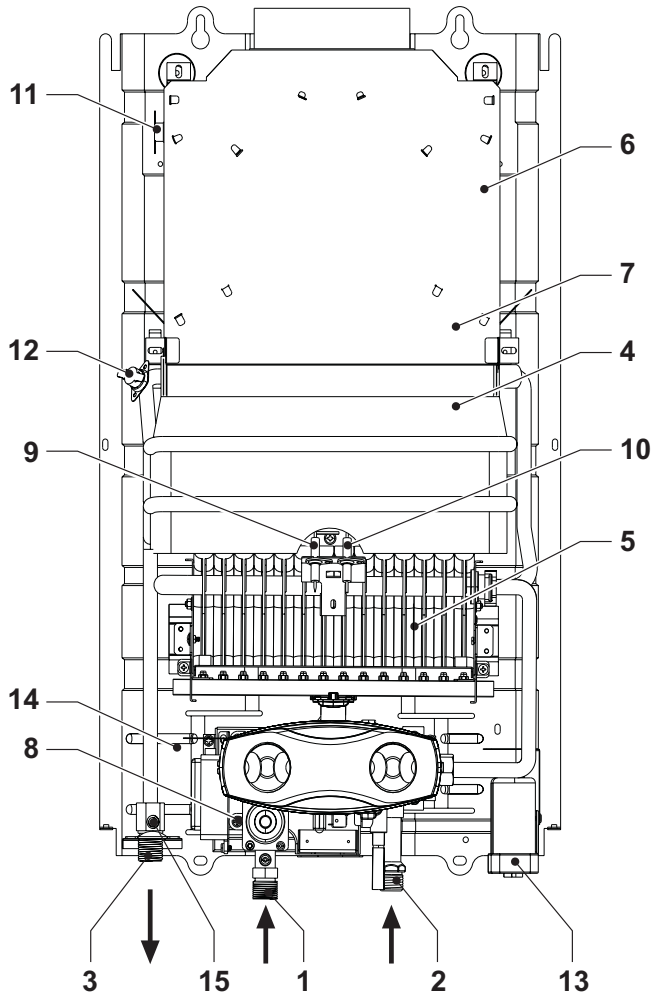

fig. 24 - Overview JEREZ ECO 14

- |                               |                                 |
|-------------------------------|---------------------------------|
| 1 Gas inlet                   | 9 Induction electrode           |
| 2 Cold water inlet            | 10 Ignition electrode           |
| 3 Hot water outlet            | 11 Flue gas sensor              |
| 4 Combustion chamber assembly | 12 Hot water temperature sensor |
| 5 Gruppo bruciatori           | 13 Battery pack                 |
| 6 Exhausthood                 | 14 Pulser                       |
| 7 Copper heat exchanger       | 15 DHW temperature sensor       |
| 8 Solenoid valve              |                                 |

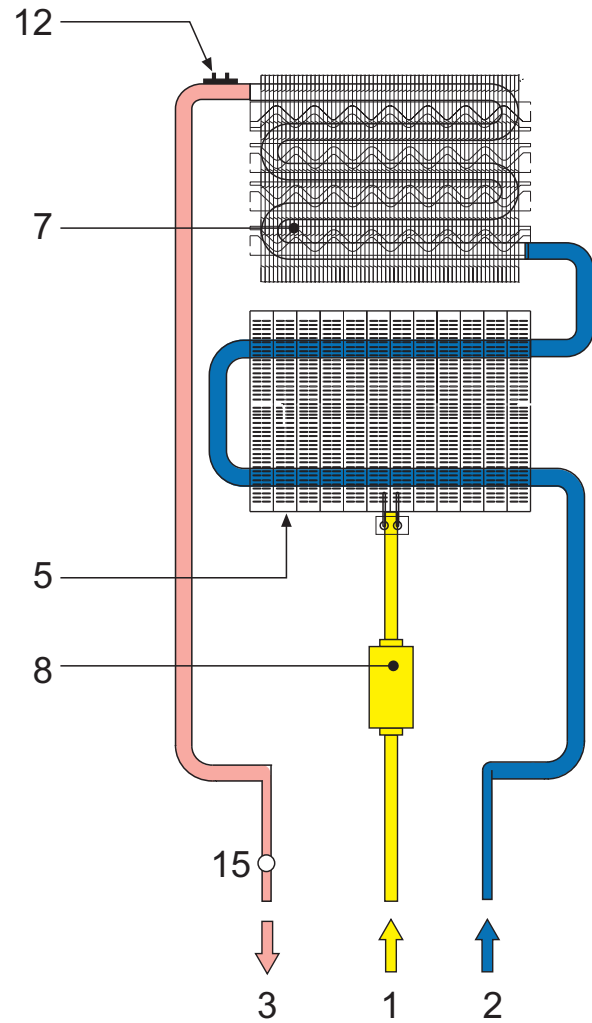

fig. 25 - Hydraulic circuit

## 4.3 Hydraulic circuit

**4.4 Technical data table**

Data	Units	JEREZ ECO 6	JEREZ ECO 11	JEREZ ECO 14	
Product identification codes G20		GCA1HKAD	GCA1MKAD	GCA1PKAD	
Product identification codes G31		GCA1HLAD	GCA1MLAD	GCA1PLAD	
Countries of destination		IT - RO - PL			
Gas category		II2HM3+ (IT) - II2ELW3B/P (PL) - II2H3B/P (RO)			
Maximum heat capacity	kW	11.8	21.1	26.8	Q
Minimum heat capacity	kW	6.3	8.1	10.7	Q
Maximum heat capacity	kW	10.4	18.9	23.8	
Minimum heat capacity	kW	5.4	7.0	9.3	
Performance at max. power	%	87	87	87	
Burner injectors G20	n. x Ø	14 x 0.82	24 x 0.85	28 x 0.85	
Gas supply pressure G20	mbar	20	20	20	
Maximum gas delivery G20	m <sup>3</sup> /h	1.25	2.23	2.84	
Minimum gas delivery G20	m <sup>3</sup> /h	0.67	0.86	1.13	
Burner injectors G230	n. x Ø	14 x 0.95	24 x 0.95	28 x 0.95	
Gas supply pressure G230	mbar	20	20	20	
Maximum gas delivery G230	m <sup>3</sup> /h	0.97	1.73	2.20	
Minimum gas delivery G230	m <sup>3</sup> /h	0.52	0.66	0.88	
Burner injectors G31/G30	n. x Ø	8 x 0.49 6 x 0.47	18 x 0.49 6 x 0.47	18 x 0.50 10 x 0.47	
Gas supply pressure G31/G30	mbar	37	37	37	
Max. gas delivery G31/G30	kg/h	0.92	1.64	2.08	
Min. gas delivery G31/G30	kg/h	0.49	0.63	0.83	
NOx emission class	-	6 (<56 mg/kWh)			NOx
Max. operating pressure	bar	10	10	10	PMS
Min. operating pressure	bar	0.2	0.2	0.2	
DHW delivery Δ25°	l/min	6.0	10.8	13.6	
DHW delivery Δ30°	l/min	5.0	9	11.4	
Degree of protection	IP	X4D			
Supply voltage	V/Hz	3V =			
Absorbed electrical power	W	/	/	/	
Empty weight	Kg	8.5	9.50	13.50	
Type of unit		B11BS			

## ErP product fiche (Models NG)

**Trademark:** LAMBORGHINI

**Type:** Conventional water heater

Item	Symbol	Unit	Value		
			JEREZ ECO 6 GCA1HKAD	JEREZ ECO 11 GCA1MKAD	JEREZ ECO 14 GCA1PKAD
Declared load profile			XS	M	M
Water heating energy efficiency class (from A+ to F)			A	A	A
Daily electricity consumption	<b>Qelec</b>	<b>kWh</b>	0,000	0,000	0,000
Annual electricity consumption	<b>AEC</b>	<b>kWh</b>	0	0	0
Water heating energy efficiency	<b>NWh</b>	<b>%</b>	78	76	74
Daily fuel consumption	<b>Qfuel</b>	<b>kWh</b>	2,874	8,185	8,562
Annual fuel consumption	<b>AFC</b>	<b>GJ</b>	2	6	6
Thermostat temperature settings of the water heater, as placed on the market			MAX	MAX	MAX
Sound power level	<b>LWA</b>	<b>dB</b>	57	58	59
Emissions of nitrogen oxides	<b>NOx</b>	<b>mg/kWh</b>	52	37	42

## ErP product fiche (Models LPG)

**Trademark:** LAMBORGHINI

**Type:** Conventional water heater

Item	Symbol	Unit	Valore		
			JEREZ ECO 6 GCA1HLAD	JEREZECO 11 GCA1MLAD	JEREZECO 14 GCA1PLAD
Declared load profile			XS	M	M
Water heating energy efficiency class (from A+ to F)			A	A	A
Daily electricity consumption	<b>Qelec</b>	<b>kWh</b>	0,000	0,000	0,000
Annual electricity consumption	<b>AEC</b>	<b>kWh</b>	0	0	0
Water heating energy efficiency	<b>NWh</b>	<b>%</b>	78	76	74
Daily fuel consumption	<b>Qfuel</b>	<b>kWh</b>	2,874	8,185	8,562
Annual fuel consumption	<b>AFC</b>	<b>GJ</b>	2	6	6
Thermostat temperature settings of the water heater, as placed on the market			MAX	MAX	MAX
Sound power level	<b>LWA</b>	<b>dB</b>	57	58	59
Emissions of nitrogen oxides	<b>NOx</b>	<b>mg/kWh</b>	37	58	62



## 4.5 Wiring diagram

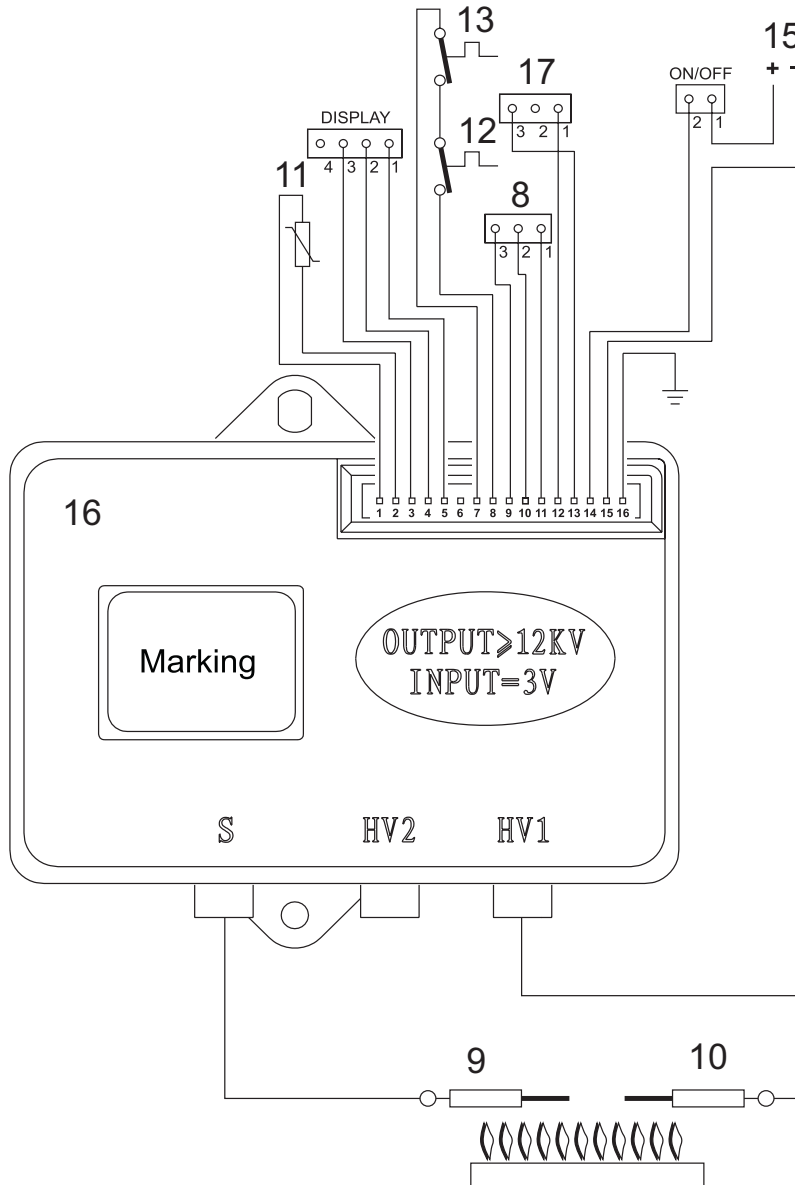

### Key

- 8 Gas valve
- 9 Detection electrode
- 10 Ignition electrode
- 11 DHW temperature sensor
- 12 Safety thermostat
- 13 Contact fume thermostat
- 15 Batteries
- 16 Electronic controller
- 17 Flow switch

fig. 26 -

Архангельск (8182)63-90-72  
 Астана (7172)727-132  
 Астрахань (8512)99-46-04  
 Барнаул (3852)73-04-60  
 Белгород (4722)40-23-64  
 Брянск (4832)59-03-52  
 Владивосток (423)249-28-31  
 Волгоград (844)278-03-48  
 Вологда (8172)26-41-59  
 Воронеж (473)204-51-73  
 Екатеринбург (343)384-55-89  
 Иваново (4932)77-34-06

Ижевск (3412)26-03-58  
 Иркутск (395)279-98-46  
 Казань (843)206-01-48  
 Калининград (4012)72-03-81  
 Калуга (4842)92-23-67  
 Кемерово (3842)65-04-62  
 Киров (8332)68-02-04  
 Краснодар (861)203-40-90  
 Красноярск (391)204-63-61  
 Курск (4712)77-13-04  
 Липецк (4742)52-20-81

Магнитогорск (3519)55-03-13  
 Москва (495)268-04-70  
 Мурманск (8152)59-64-93  
 Набережные Челны (8552)20-53-41  
 Нижний Новгород (831)429-08-12  
 Новокузнецк (3843)20-46-81  
 Новосибирск (383)227-86-73  
 Омск (3812)21-46-40  
 Краснодар (861)203-40-90  
 Орел (4862)44-53-42  
 Оренбург (3532)37-68-04  
 Пенза (8412)22-31-16

Пермь (342)205-81-47  
 Ростов-на-Дону (863)308-18-15  
 Рязань (4912)46-61-64  
 Самара (846)206-03-16  
 Санкт-Петербург (812)309-46-40  
 Саратов (845)249-38-78  
 Севастополь (8692)22-31-93  
 Симферополь (3652)67-13-56  
 Смоленск (4812)29-41-54  
 Сочи (862)225-72-31  
 Ставрополь (8652)20-65-13

Сургут (3462)77-98-35  
 Тверь (4822)63-31-35  
 Томск (3822)98-41-53  
 Тула (4872)74-02-29  
 Тюмень (3452)66-21-18  
 Ульяновск (8422)24-23-59  
 Уфа (347)229-48-12  
 Хабаровск (4212)92-98-04  
 Челябинск (351)202-03-61  
 Череповец (8202)49-02-64  
 Ярославль (4852)69-52-93

Киргизия (996)312-96-26-47

Россия (495)268-04-70

Казахстан (772)734-952-31