

Архангельск (8182)63-90-72
Астана (7172)727-132
Астрахань (8512)99-46-04
Барнаул (3852)73-04-60
Белгород (4722)40-23-64
Брянск (4832)59-03-52
Владивосток (423)249-28-31
Волгоград (844)278-03-48
Вологда (8172)26-41-59
Воронеж (473)204-51-73
Екатеринбург (343)384-55-89
Иваново (4932)77-34-06

Ижевск (3412)26-03-58
Иркутск (395)279-98-46
Казань (843)206-01-48
Калининград (4012)72-03-81
Калуга (4842)92-23-67
Кемерово (3842)65-04-62
Киров (8332)68-02-04
Краснодар (861)203-40-90
Красноярск (391)204-63-61
Курск (4712)77-13-04
Липецк (4742)52-20-81

Магнитогорск (3519)55-03-13
Москва (495)268-04-70
Мурманск (8152)59-64-93
Набережные Челны (8552)20-53-41
Нижегород (831)429-08-12
Новокузнецк (3843)20-46-81
Новосибирск (383)227-86-73
Омск (3812)21-46-40
Орел (4862)44-53-42
Оренбург (3532)37-68-04
Пенза (8412)22-31-16

Пермь (342)205-81-47
Ростов-на-Дону (863)308-18-15
Рязань (4912)46-61-64
Самара (846)206-03-16
Санкт-Петербург (812)309-46-40
Саратов (845)249-38-78
Севастополь (8692)22-31-93
Симферополь (3652)67-13-56
Смоленск (4812)29-41-54
Сочи (862)225-72-31
Ставрополь (8652)20-65-13

Сургут (3462)77-98-35
Тверь (4822)63-31-35
Томск (3822)98-41-53
Тула (4872)74-02-29
Тюмень (3452)66-21-18
Ульяновск (8422)24-23-59
Уфа (347)229-48-12
Хабаровск (4212)92-98-04
Челябинск (351)202-03-61
Череповец (8202)49-02-64
Ярославль (4852)69-52-93

Киргизия (996)312-96-26-47

Россия (495)268-04-70

Казахстан (772)734-952-31

<https://lamborghini.nt-rt.ru/> || hgc@nt-rt.ru



00HY2YKD - Cod. AT3022660 - 2020-12



KYRA D 30 SI UNIT COND

EN

INSTRUCTIONS FOR USE, INSTALLATION AND MAINTENANCE

INDEX

1. GENERAL INFORMATION 36

2. OPERATING INSTRUCTIONS 36

2.1 Introduction..... 36

2.2 Control panel 36

2.3 Lighting and turning off..... 37

2.4 Adjustments 37

3. INSTALLATION OF THE APPLIANCE 38

3.1 General Instructions 38

3.2 Place of installation 38

3.3 Plumbing connections 38

3.4 Burner connection 40

3.5 Electrical connections..... 40

3.6 Connection to the flue 41

3.7 Condensate drain connection..... 41

4. SERVICE AND MAINTENANCE..... 41

4.1 Adjustments..... 41

4.2 Commissioning..... 43

4.3 Maintenance..... 44

4.4 Troubleshooting..... 44

5. TECHNICAL DATA AND CHARACTERISTICS 46

5.1 Main components, dimensions and connections..... 46

5.2 Water circuit..... 47

5.3 Diagrams 47

5.4 Technical data table..... 48

5.5 Wiring diagram 50



The unit and its accessories must be appropriately disposed of in compliance with current regulations.

1. GENERAL INFORMATION

- Carefully read the warnings in this instruction booklet
- Once the boiler is installed, show its operation to the user and deliver this instruction manual, which is an integral and essential part of the product and must be carefully stored so that it can be consulted at any time.
- Installation and maintenance must be carried out by professionally qualified personnel, according to current regulations and the manufacturer's instructions. It is forbidden to handle any sealed regulation device.
- Incorrect installation or poor maintenance can cause damage or physical injury. The manufacturer declines any responsibility for damage caused by errors in installation and use or by failure to follow the manufacturer's instructions. Before carrying out any cleaning or maintenance operation, disconnect the unit from the power supply using the system switch and/or the special cut-off devices.
- Before carrying out any cleaning or maintenance operation, disconnect the unit from the power supply using the system switch and/or the special cut-off devices.
- In case of a fault and/or poor operation, deactivate the unit and do not try to repair it or directly intervene. Contact professionally qualified personnel. Any repair/replacement of the products must only be carried out by qualified personnel using genuine parts. Failure to comply with the above can compromise the safety of the unit. This unit must only be used for its intended purpose.
- This unit must only be used for its intended purpose
- Any other use is deemed improper and therefore hazardous.
- Do not leave the packaging elements within the reach of children as they are dangerous.
- The unit can be used by children aged at least 8 years and by persons with reduced physical, sensory or mental capabilities, or lacking experience or the necessary knowledge, only if under supervision or they have received instructions on its safe use and the related risks. Children must not play with the unit. Cleaning and maintenance intended to be done by the user can be carried out by children aged at least 8 years only if under supervision.
- The unit and its accessories must be appropriately disposed of in compliance with current regulations.
- The images given in this manual are a simplified representation of the product. In this representation there may be slight and insignificant differences with respect to the product supplied.

2. OPERATING INSTRUCTIONS

2.1 Introduction

Dear Customer,

Thank you very much for choosing **KYRA D 30 SI UNIT COND**, a **LAMBORGHINI** standing boiler with advanced design, state-of-the-art technology, high reliability and constructive quality. Please read this manual carefully, as it provides important information about installation, use and maintenance.

KYRA D 30 SI UNIT COND is a thermal generator for heating, with **condensation**, high performance and low emission level.

The **boiler body** is made of carbon steel and high quality stainless steel; inside it houses a stainless steel coil for DHW production. **The burner is pressurized.**

2.2 Control panel

Panel

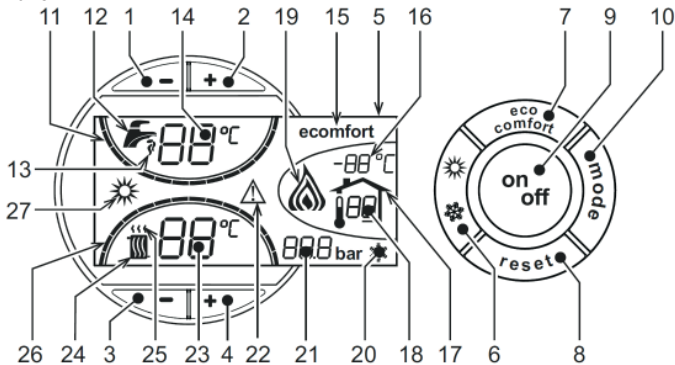

fig.1 – Control panel

Panel key

- 1 = DHW temperature setting decrease button
- 2 = DHW temperature setting increase button
- 3 = Heating system temperature setting decrease button
- 4 = Heating system temperature setting increase button
- 5 = Display
- 6 = Summer / Winter mode selection button
- 7 = Economy / Comfort mode selection button

- 8 = Reset button
- 9 = Unit On / Off button
- 10 = "Sliding Temperature" menu button
- 11 = Set DHW temperature reached
- 12 = DHW symbol
- 13 = DHW mode
- 14 = DHW outlet temperature / setting
- 15 = Eco (Economy) or Comfort mode
- 16 = External sensor temperature (with optional external probe)
- 17 = Appears on connecting the external Probe or the Remote Timer Control (optionals)
- 18 = Room temperature (with optional Remote Timer Control)
- 19 = Burner On
- 20 = Antifreeze operation
- 21 = Heating system pressure
- 22 = Fault
- 23 = Heating delivery temperature/setting
- 24 = Heating symbol
- 25 = Heating mode
- 26 = Set heating delivery temperature reached
- 27 = Summer mode

Indication during operation

Heating

A heating demand (generated by the Room Thermostat or Remote Timer Control) is indicated by flashing of the hot air above the radiator (details 24 and 25 - fig.1).

The heating graduation marks (detail 26 - fig.1) light up as the heating sensor temperature reaches the set value.

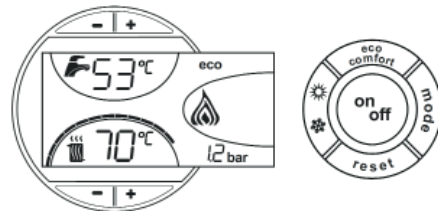

fig.2

DHW (Comfort)

A DHW demand (generated by drawing domestic hot water) is indicated by flashing of the hot water under the tap (details 12 and 13 - fig.1).

The DHW graduation marks (detail 11 - fig.1) light up as the DHW sensor temperature reaches the set value.

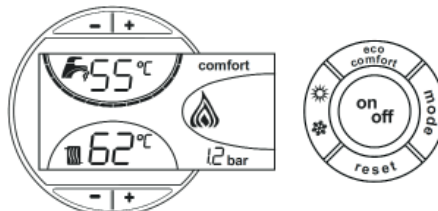

fig.3

Comfort mode (to have DHW service the Comfort must be activated)

The need to reset the internal temperature of the boiler (Comfort mode) is signaled by the blinking of the respective symbol (15 and 13 - Fig.1)

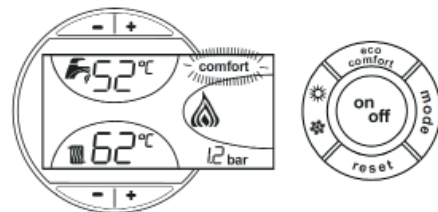

fig.4

2.3 Lighting and turning off

Boiler not electrically powered

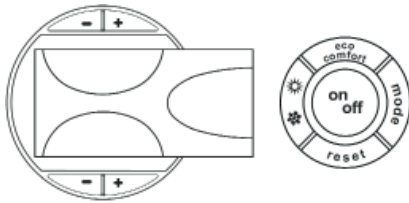

fig.5 - Boiler not electrically powered



The antifreeze system does not work when the power and/or gas to the unit are turned off. To avoid damage caused by freezing during long idle periods in winter, it is advisable to drain all water from the boiler, DHW circuit and system; or drain just the DHW circuit and add a suitable antifreeze to the heating system, complying with that prescribed in sec.3.3.

Boiler lighting

- Open the fuel on-off valves.
- Switch on the power to the unit.

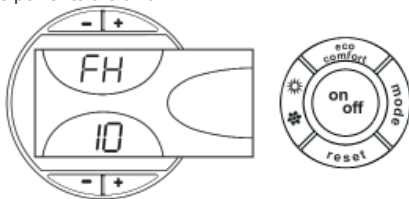

fig.6 - Boiler lighting

- For the following 120 seconds the display will show FH which identifies the heating system air venting cycle.
- During the first 5 seconds the display will also show the card software version.
- When the message FH disappears, the boiler is ready to operate automatically whenever domestic hot water is drawn or in case of a room thermostat demand.

Turning the boiler off

Press the on/off button (detail 9 - fig.1) for 1 second.

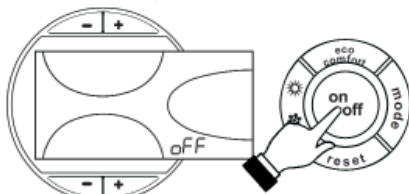

fig.7 - Turning the boiler off

When the boiler is turned off, the PCB is still powered.

Domestic hot water and heating are disabled.

The antifreeze system remains activated. To relight the boiler, press the on/off button (detail 9 - fig.1) again for 1 second.

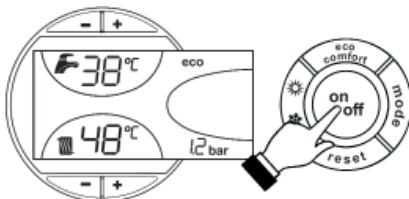

fig.8

The boiler will be immediately ready to operate whenever domestic hot water is drawn or in case of a room thermostat demand.

2.4 Adjustments

Summer/Winter Switchover

Press the summer/winter button (detail 6 - fig.1) for 1 second.

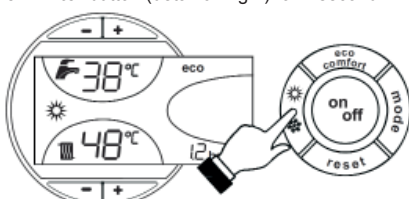

fig.9

The display activates the Summer symbol (detail 27 - fig.1): the boiler will only deliver domestic hot water. The antifreeze system remains activated.

To deactivate the Summer mode, press the summer/winter button (part. 6 - fig.1) again for 1 second.

Heating temperature setting

Use the heating buttons (details 3 and 4 - fig.1) to adjust the temperature from a min. of 30°C to a max. of 80°C.

In any case it is advisable not to operate the boiler below 45°C.

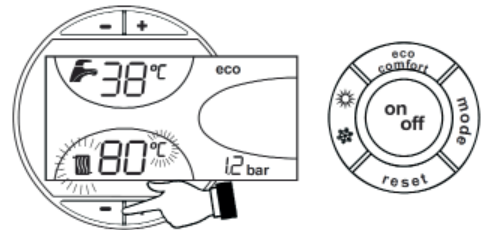

fig.10

DHW temperature adjustment

Use the DHW buttons -/+ (details 1 and 2 - fig.1) to adjust the temperature from a min. of 10°C to a max. of 65°C.

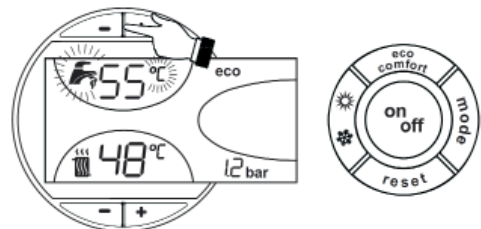

fig.11

Room temperature adjustment (with optional room thermostat)

Using the room thermostat, set the temperature desired in the rooms. If the room thermostat is not installed the boiler will keep the heating system at its setpoint temperature.

Room temperature adjustment (with optional remote timer control)

Using the remote timer control, set the temperature desired in the rooms. The boiler unit will set the system water according to the required room temperature. For information on the remote timer control, please refer to its user's manual.

Sliding temperature

When the optional external probe is installed the control panel display (detail 5 - fig.1) shows the actual outside temperature read by the probe. The boiler control system operates with "Sliding Temperature". In this mode, the temperature of the heating system is adjusted according to the outside weather conditions, in order to ensure high comfort and energy saving throughout the year. In particular, as the outside temperature increases, the system delivery temperature is decreased according to a specific "compensation curve".

With Sliding Temperature adjustment, the temperature set with the heating buttons -/+ (details 3 and 4 - fig.1) becomes the maximum system delivery temperature. It is advisable to set a maximum value to allow system adjustment throughout its useful operating range.

The boiler must be adjusted at the time of installation by qualified personnel. Possible adjustments can in any case be made by the user to improve comfort.

Compensation curve and curve offset

Press the mode button (detail 10 - fig.1) once to display the actual compensation curve (fig.11), which can be modified with the DHW buttons (details 1 and 2 - fig.1).

Adjust the required curve from 1 to 10 according to the characteristic (fig.13).

By setting the curve to 0, sliding temperature adjustment is disabled.

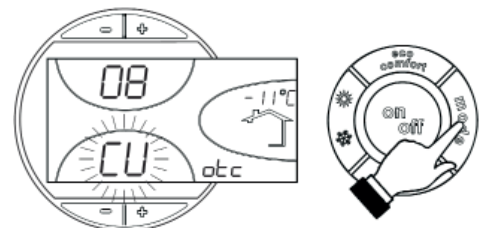

fig.12 - Compensation curve

Press the heating buttons (details 3 and 4 - fig.1) to access parallel curve offset (fig.14), modifiable with the DHW buttons (details 1 and 2 - fig.1).

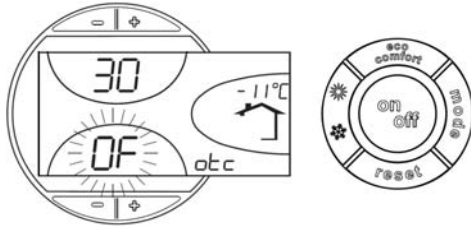

fig.13 - Curve parallel offset

Press the **mode** button (detail 10 - fig.1) again to exit parallel curve adjustment mode.

If the room temperature is lower than the required value, it is advisable to set a higher order curve and vice versa. Proceed by increasing or decreasing in steps of one and check the result in the room.

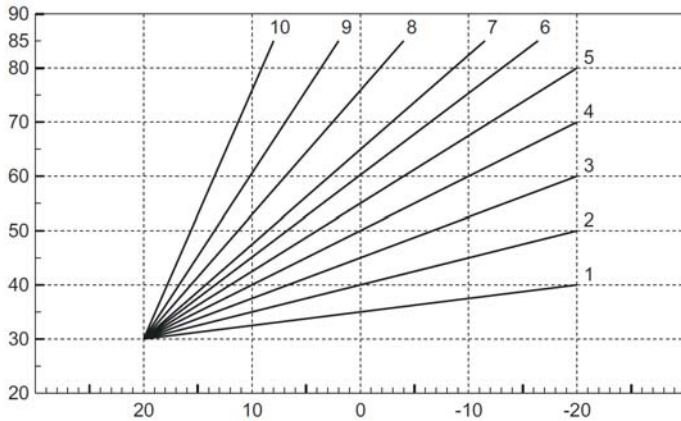

fig.14 - Compensation curves

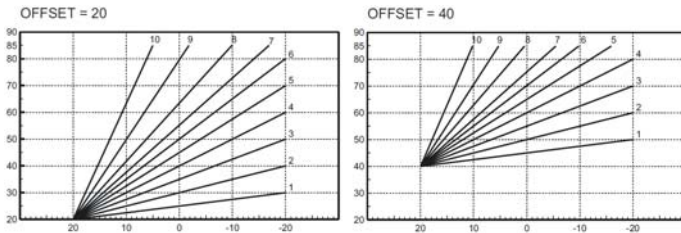

fig.15 - Example of compensation parallel curve offset

Adjustments from Remote Timer Control

If the Remote Timer Control (optional) is connected to the boiler, the above adjustments are managed according to that given in table 1. Also, the control panel display (detail 5 - fig.1) shows the actual room temperature detected by the Remote Timer Control.

Table. 1

Heating temperature setting	Adjustment can be made from the Remote Timer Control menu and the boiler control panel.
DHW temperature adjustment	Adjustment can be made from the Remote Timer Control menu and the boiler control panel.
Summer/Winter Switchover	Summer mode has priority over a possible Remote Timer Control heating demand.
Eco/Comfort selection	On disabling DHW from the Remote Timer Control menu, the boiler selects the Economy mode. In this condition, the button 7 - fig.1 on the boiler panel is disabled
	On enabling DHW from the Remote Timer Control menu, the boiler selects the Comfort mode. In this condition it is possible to select one of the two modes with the button 7 - fig.1 on the boiler panel.
Sliding Temperature	Both the Remote Timer Control and the boiler card manage Sliding Temperature adjustment: of the two, the Sliding Temperature of the boiler card has priority.

Water system pressure adjustment

The filling pressure with system cold, read on the display, must be approx. 1.0 bar. If the system pressure falls to values below minimum, the boiler card will activate fault F37 (fig.16).

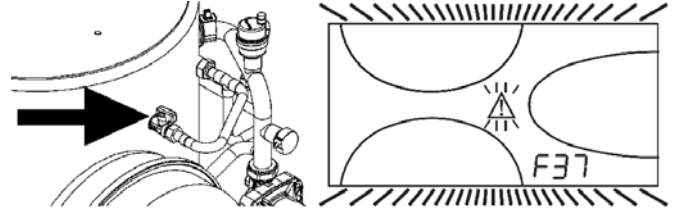

fig.16 - Low system pressure fault

Once the system pressure is restored, the boiler will activate the 120-second venting cycle indicated on the display by FH.

3. INSTALLATION OF THE APPLIANCE

3.1 General Instructions

BOILER INSTALLATION MUST ONLY BE PERFORMED BY QUALIFIED PERSONNEL, IN ACCORDANCE WITH ALL THE INSTRUCTIONS GIVEN IN THIS TECHNICAL MANUAL, THE PROVISIONS OF CURRENT LAW, THE PRESCRIPTIONS OF NATIONAL AND LOCAL STANDARDS AND THE RULES OF PROPER WORKMANSHIP.

3.2 Place of installation

The boiler unit must be installed in a specific room with ventilation openings to the outside as prescribed by current regulations. If there are several burners or suction units that can work together in the same room, the ventilation openings must be sized for simultaneous operation of all the units. The place of installation must be free of flammable materials or objects, corrosive gases, powders or volatile substances that, conveyed by the burner fan, can obstruct the internal lines of the burner or the combustion head. The room must be dry and not exposed to rain, snow or frost.

If the unit is enclosed in a cabinet or mounted alongside, a space must be provided for removing the casing and for normal maintenance operations.

3.3 Plumbing connections

The heating capacity of the unit must be previously established by calculating the building's heat requirement according to the current regulations. The system must be provided with all the components for correct and regular operation.

It is advisable to install shutoff valves between the boiler and heating system allowing the boiler to be isolated from the system if necessary.

The safety valve outlet must be connected to a funnel or collection pipe to prevent water spurring onto the floor in case of overpressure in the heating circuit. Otherwise, if the discharge valve cuts in and floods the room, the boiler manufacturer cannot be held liable.

Do not use the water system pipes to earth electrical appliances.

Before installation, flush all the pipes of the system thoroughly to remove any residuals or impurities that could affect proper operation of the unit.

Carry out the relevant connections according to the diagram in cap. 5 and the symbols given on the unit.

High efficiency circulating pump

Circulating pump adjustment with boiler connected to an external storage tank.

The circulating pump is factory set to "Constant Speed III" mode. This mode satisfies most installations. However, it can be set specifically according to the type of system.

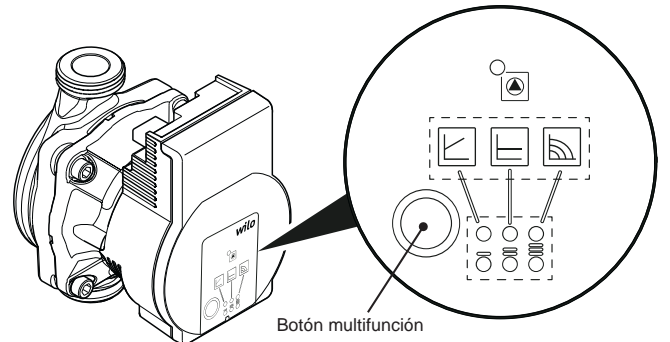

fig.17

Light indicators	
	Signalling <ul style="list-style-type: none"> In normal operation, the LED lights up green LED on/flashing in case of a fault
	Indication of selected adjustment mode $\Delta p-v$, $\Delta p-c$ and constant speed $\Delta p-v$ $\Delta p-c$ Constant Speed
	<ul style="list-style-type: none"> Indication of selected characteristic curve (I, II, III) within the adjustment mode
	<ul style="list-style-type: none"> Combined LED indications during pump venting function, manual restart and keypad lock
Control buttons	
	Press <ul style="list-style-type: none"> Select the adjustment mode Indication of selected characteristic curve (I, II, III) within the adjustment mode Long press <ul style="list-style-type: none"> Activate the pump venting function (press for 3 seconds) Activate manual restart (press for 5 seconds) Lock/unlock the button (press for 8 seconds)

Vent

- Fill and vent the system correctly.

If this does not occur:

- Activate the pump venting function by pressing the control button for 3 seconds, then release.
- The pump venting function starts and lasts 10 minutes.
- The two sets of upper and lower LEDs flash alternately at 1-second intervals.
- To stop, press the control button for 3 seconds.

ATTENTION

After venting, the LED indicator shows the pump set values.

Set the adjustment mode

Select the adjustment mode

The LED selection of the adjustment mode and the corresponding characteristic curves is done clockwise.

- Press the control button briefly (about 1 second).
- The LEDs show the adjustment mode and characteristic curves set.

The possible settings are shown below (e.g. constant speed/characteristic curve III)

LED indicator	Adjustment mode	Characteristic curve
	Constant speed	II
	Constant speed	I
	Variable differential pressure $\Delta p-v$	III
	Variable differential pressure $\Delta p-v$	II
	Variable differential pressure $\Delta p-v$	I
	Constant differential pressure $\Delta p-c$	III
	Constant differential pressure $\Delta p-c$	II
	Constant differential pressure $\Delta p-c$	I
	Constant speed	III

- Pressing the button 9 times restores the basic setting (constant speed/characteristic curve III)

Lock/unlock button

- Activate the keypad lock by pressing the control button for 8 seconds, until the LEDs of the selected setting flash briefly and then release.
- The LEDs flash continuously at 1-second intervals.
- If the keypad lock is activated, the pump settings can no longer be changed.
- Deactivation of the keypad lock occurs in the same way as activation.

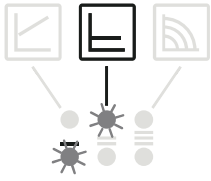

ATTENTION

In case of a power failure, all settings and displays remain stored.

Factory setting activation

The factory setting is activated by pressing and holding the control button and deactivating the pump.

- Press the control button continuously for at least 4 seconds.
- All LEDs flash for 1 second.
- The LEDs of the last setting flash for 1 second.

On restarting the pump, it will work with the factory setting (delivery status).

Manual restart

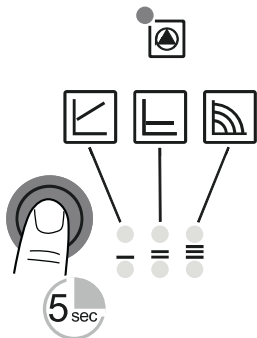

- When a blockage is detected, the pump tries to restart automatically.
- If the pump does not restart automatically:
 - Activate manual restart by pressing the control button for 5 seconds, then release.
 - The restart function starts and lasts max. 10 minutes.
 - The LEDs flash clockwise one after the other.
 - To stop, press the control button for 5 seconds.

ATTENTION

After restarting, the LED indicator shows the previously set pump values.

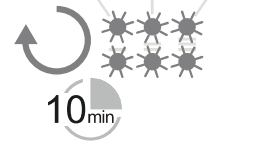

If it is not possible to eliminate a fault, contact a system installer or Customer Service

System water characteristics

In case of water with hardness exceeding 25° Fr (1°F = 10ppm CaCO₃), use suitably treated water to prevent possible encrustations in the boiler. Treatment must not reduce the hardness to values below 15°F (Decree 236/88 on water intended for human consumption). However, treatment of the water is essential in case of very large systems or frequent system water replenishment.

Frost protection system, antifreeze liquids, additives and inhibitors

A frost protection system activates the boiler in heating mode when the system flow temperature drops below 6°C. The device is not active if the power and/or gas supply to the unit are disconnected. If necessary, the use of antifreeze liquids, additives and inhibitors is allowed, only and exclusively if their manufacturer provides a guarantee ensuring that the products are suitable for use and do not cause damage to the boiler exchanger or to other components and/or materials of the boiler and system. The use of antifreeze liquids, additives and generic inhibitors, not specifically suitable for use in heating systems compatible with the boiler and system materials, is prohibited.

3.4 Burner connection

The burner is equipped with flexible pipes and a filter for connection to the oil feed line. Run the flexible pipes out of the back and install the filter as indicated in fig.20.

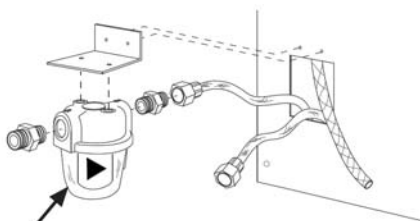

ATTENTION TO THE SENSE OF THE FILTER

fig.18 - Fuel filter installation

The oil feed circuit must be made according to one of the following diagrams, without exceeding the pipe lengths (LMAX) given in the table.

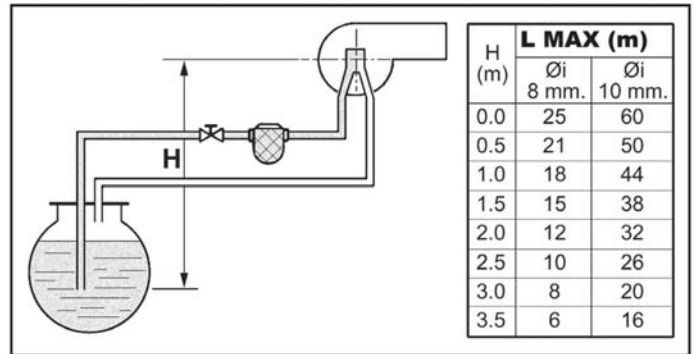

fig.19 - Suction feed

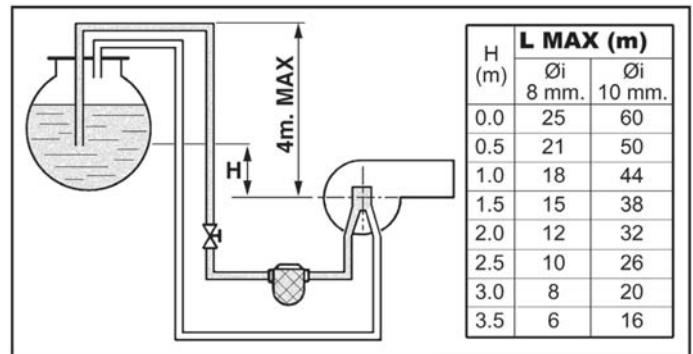

fig.20 - Siphon feed

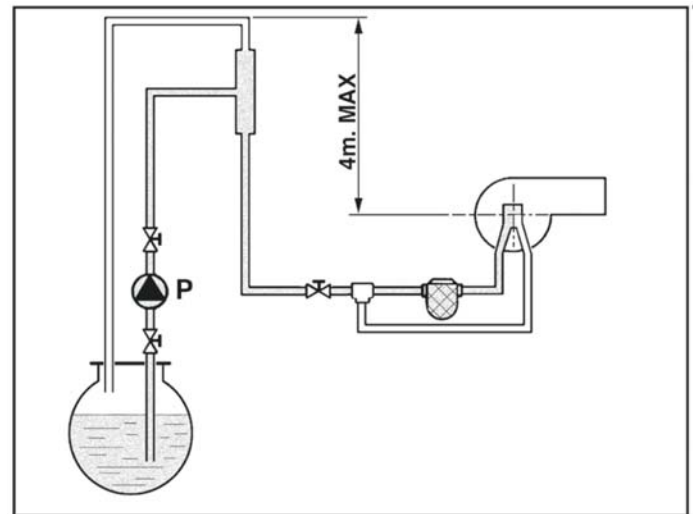

fig.21 - Ring feed

3.5 Electrical connections

Connection to the electrical grid



The unit's electrical safety is only guaranteed when correctly connected to an efficient earthing system executed according to current safety standards. Have the efficiency and suitability of the earthing system checked by professionally qualified personnel. The manufacturer is not responsible for any damage caused by failure to earth the system. Also make sure that the electrical system is adequate for the maximum power absorbed by the unit, as specified on the boiler dataplate.

The boiler is prewired and provided with a Y-cable and plug for connection to the electricity line. The connections to the grid must be made with a permanent connection and equipped with a bipolar switch whose contacts have a minimum opening of at least 3mm, interposing fuses of max. 3A between the boiler and the line. It is important to respect the polarities (LINE: brown wire / NEUTRAL: blue wire / EARTH: yellow-green wire) in making connections to the electrical line. During installation or when changing the power cable, the earth wire must be left 2 cm longer than the others.



The user must never change the unit's power cable. If the cable gets damaged, switch off the unit and have it changed solely by professionally qualified personnel. If changing the electric power cable, use solely "HAR H05 VV-F" 3x0.75mm² cable with a maximum outside diameter of 8 mm.

Room thermostat (optional)(remove the existing bridge terminals 17-18)



IMPORTANT: THE ROOM THERMOSTAT MUST HAVE VOLTAGE-FREE CONTACTS. CONNECTING 230 V TO THE ROOM THERMOSTAT TERMINALS WILL PERMANENTLY DAMAGE THE ELECTRONIC BOARD.

When connecting time controls or a timer, do not take the power supply for these devices from their breaking contacts. Their power supply must be by means of direct connection from the mains or with batteries, depending on the kind of device. a las pilas, según el tipo de dispositivo.

Accessing the electrical terminal block

Undo the two screws "A" located on the top part of the control panel and remove the cover.

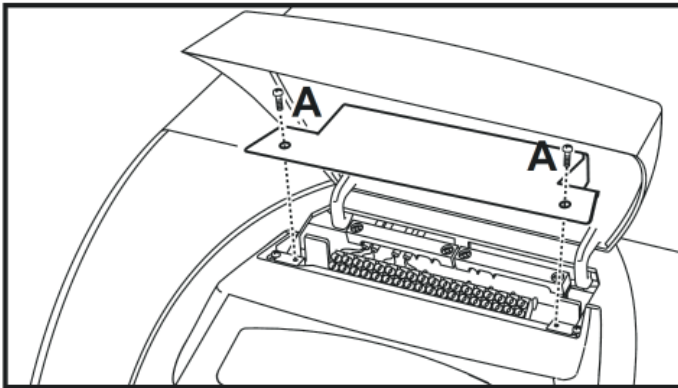

fig.22 - Accessing the terminal block

3.6 Connection to the flue

The unit must be connected to a flue designed and built in compliance with the current regulations. The pipe between the boiler and flue must be made from material suitable for the purpose, i.e. heat and corrosion resistant. Ensure the seal at the joints. At the points of union it is recommended to check the tightness and thermally insulate the entire duct between the boiler and chimney, in order to avoid the formation of condensation.

3.7 Condensate drain connection

The unit's condensate drain must be connected to a suitable disposal system. Comply with the specific local and national regulations on discharging condensate water into the waste water disposal system. For boilers not using exclusively low-sulphur gas oil (S content < 50 ppm) make sure to provide for a suitable condensate neutralisation device.

Connect the condensate drain pipe located at the back of the boiler (fig.25) to the neutralisation device connected to the waste water system. The condensate discharge pipes must be acidproof and installed sloping at least 3° towards the drain, with-out any constrictions and obstructions.



IMPORTANT. Fill the trap with water before starting the unit. Verify. Periodically check the water in the trap.

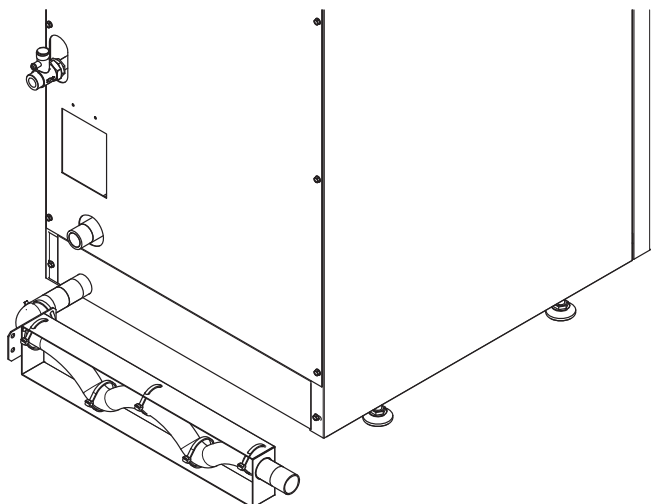

fig.23 - Condensate drain

4. SERVICE AND MAINTENANCE

All adjustment, conversion, commissioning and maintenance operations described below must only be carried out by Qualified Personnel (meeting the professional technical requirements prescribed by current regulations) such as those of the Local After-Sales Technical Service.

LAMBORGHINI declines any liability for damage and/or injury caused by unqualified and un-authorised persons tampering with the unit.

4.1 Adjustments

TEST mode activation

Press the **heating buttons** (details 3 and 4 - fig.1) together for 5 seconds to activate the **TEST** mode. The boiler switches on irrespective of the system or DHW request.

The heating symbol (detail 24 - fig.1) and DHW symbol (detail 12 - fig.1) flash on the display. **(In case of configuration for DHW)**

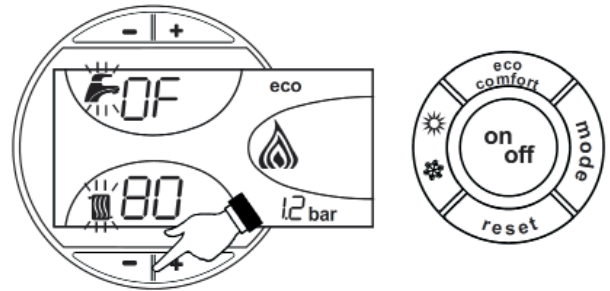

fig.24 - TEST mode

To deactivate the Test mode, repeat the activation sequence.

The TEST mode is automatically disabled in any case after 15 minutes.

Burner adjustment

The burner is factory-set as given in table 4. The burner can be set to a different output by acting on the pump pressure, nozzle, head adjustment, and air adjustment as per the following paragraphs. In any case, the new adjusted output must fall within the boiler's nominal operating range. After making any adjustments, using a combustion analyser check that the CO₂ content in the fumes is between 11% and 12%.

Nozzle flow rate table for oil

Table 2 gives the oil flow rates (in kg/h) according to the change in pump pressure and nozzles.

N.B. - The values given below are only approximate, since nozzle flow rates can vary by ± 5%. Also, with burners having a preheater, the fuel flow rate decreases by about 10%.

Table. 2

NOZZLE G.P.H.	Pump pressure (bar)						
	8	9	10	11	12	13	14
0,40	1,32	1,40	1,47	1,54	1,61	1,68	1,75
	16,6	16,6	17,43	18,26	19,09	19,92	20,75
0,50	1,57	1,65	1,73	1,81	1,89	1,97	2,05
	18,62	19,57	20,51	21,5	22,42	23,36	24,31
0,60	1,93	2,01	2,23	2,32	2,42	2,52	2,64
	22,89	23,83	26,44	27,51	28,7	29,88	31,31
0,65	2,12	2,25	2,4	2,63	2,74	2,8	2,91
	25,14	26,68	28,46	31,19	32,49	33,21	34,51
0,75	2,50	2,65	2,8	2,95	3,07	3,2	3,33
	29,65	31,43	33,21	34,99	36,41	37,95	39,49
0,85	2,92	3,1	3,27	3,45	3,6	3,75	3,9
	34,63	36,76	38,78	40,92	42,69	44,47	46,25
1,00	3,30	3,5	3,67	3,85	4,02	4,2	
	39,13	41,51	43,52	45,66	47,67	48,72	51,95

Flow rate at nozzle outlet in kg/h

Pump pressure adjustment

The pump is factory-set to 14 bar. Use an oil bath gauge to check the pressure. The pressure can be adjusted between 11 and 14 bar.

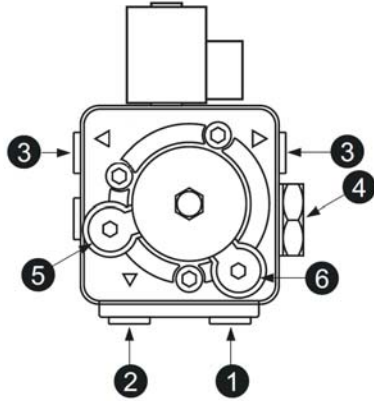

fig.25 - Pump ITALPUMP

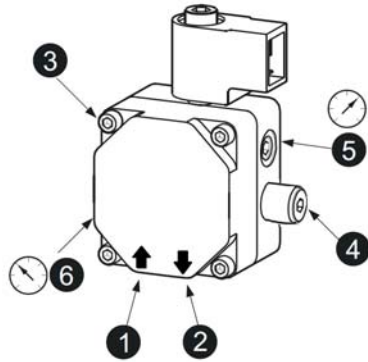

fig.26 - Pump DANFOSS

1. Suction Ø1/4"
2. Return Ø1/4"
3. Oil delivery Ø1/8"
4. Pressure adjustment
5. Pressure gauge connection Ø1/8"
6. Vacuum gauge connection Ø1/8"

Combustion head adjustment

The head is adjusted by means of the screw 1, according to the indications of the pointer 2.

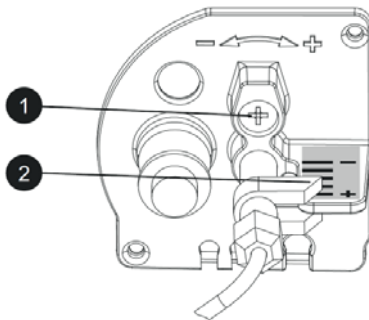

fig.27

Air damper adjustment

After loosening the screw 3, operating the screw 1, the combustion air is adjusted according to the indications of the pointer 2. After adjustment, lock the screw 3.

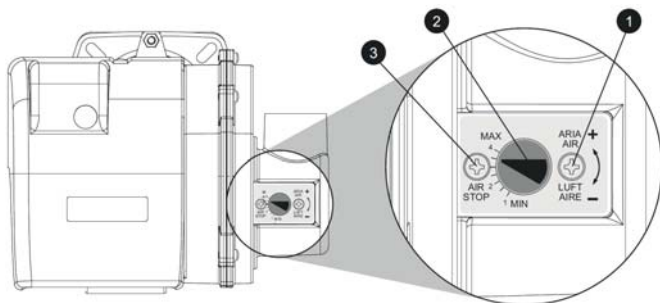

fig.28

Position of electrodes - baffle

After fitting the nozzle, check correct positioning of the electrodes and baffle, according to the dimensions given below. It is advisable to check the dimensions after each operation on the head.

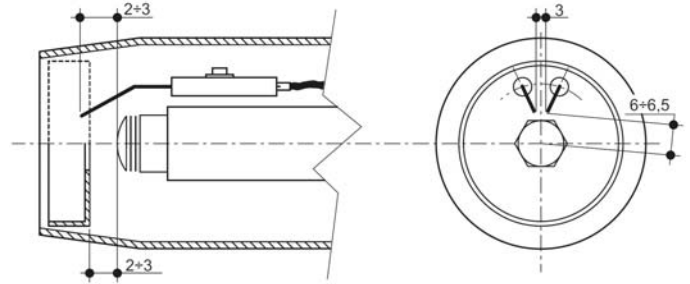

fig.29 - Position of electrodes - baffle

Service Menu

The card Service Menu is accessed by pressing the Reset button for 10 seconds. Press the Heating buttons to choose "tS", "In", "Hi" or "rE". "tS" means Transparent Parameters Menu, "In" means Information Menu, "Hi" means History Menu, "rE" means History Menu Reset. After selecting the Menu, press the Reset button to access it

"tS" - Transparent Parameters Menu

The card is equipped with 27 transparent parameters also modifiable from Remote Control (Service Menu):

Index	Description	Range	Default
P01	System water pressure protection selection	0 = Pressure switch	1
		1 = Pressure transducer	
P02	Boiler type selection	1 = Heating only	4
		2 = Storage with probe	
		3 = Storage with thermostat	
		4 = Instantaneous	
		5 = Instantaneous Combi	
		6 = Storage with probe	
		7 = Instantaneous Combi with DHW probe	
P03	Heating pump activation temperature	0-80°C	30°C
P04	Heating pump Post-Circulation	0 + 20 minutes	6 minutes
P05	Heating standby time	0 + 10 minutes	2 minutes
P06	Pump operation	0 = Post-Circulation 1 = Continuous	0
P07	Pump deactivation temperature during Post-Circulation	0 + 100°C	35°C
P08	Heating user max. setpoint	31 + 90°C	80°C
P09	DHW pump deactivation temperature	0 + 80°C	40°C
P10	DHW pump Post-Circulation	0 + 255 seconds	30 seconds
P11	DHW standby time	0 + 255 seconds	120 seconds
P12	No function	--	--
P13	No function	--	--
P14	Flow adjustment temperature in DHW mode	50 + 75°C	70°C
P15	Comfort mode activation temperature	0 + 80°C	55°C
P16	Comfort mode deactivation hysteresis	0 + 20°C	5°C
P17	System min. pressure value	0 + 8 bar/10	2 bar/10
P18	System nominal pressure value	5 + 20 bar/10	6 bar/10
P19	No function	--	--
P20	Mains Voltage Frequency	0 = 50Hz 1 = 60Hz	0
(21)	Fume temperature sensor enabling	0 = Disabled 1 = Enabled	1
(22)	Fumes Max Temperature	0 + 125°C	100°C

Index	Description	Range	Default
(23)	No function	--	30%
(24)	No function	--	75%
(25)	No function	--	100%
(26)	No function	--	18°C
(27)	No function	--	35°C

Press the Heating buttons to scroll the list of parameters in increasing or decreasing order. To change the value of a parameter just press the DHW buttons: the change will be saved automatically.

Press the Reset button to return to the Service Menu. Press the Reset button for 10 seconds to exit to the card Service Menu.

"In" - Information Menu

The card can display the following information:

t01	NTC Heating sensor (°C)	between 05 and 125°C
t02	Hot water tank NTC sensor (°C) (Only with Parameter P02=2, boiler with storage or with Parameter P02=6, boiler with storage)	between 05 and 125°C
t03	NTC Safety sensor (°C)	between 05 and 125°C
t04	NTC External sensor (°C)	between -30 and 70°C (Negative values flash)
P05	Actual system water pressure (bar/10)	00-99 bar/10
t06	NTC DHW sensor (°C) (Only with Parameter P02=7, Instant. Combi boiler Combi with DHW sensor)	between 05 and 125°C
t07	NTC Fume sensor (°C) (Only with Parameter P21=1, fume sensor Enabled)	between 05 and 125°C

Press the Heating buttons to scroll the list of information. In case of damaged sensor, the card displays hyphens.

Press the Reset button to return to the Service Menu. Press the Reset button for 10 seconds to exit to the card Service Menu.

"Hj" - History Menu

The microprocessor is able to store the total hours with card powered (Ht), the last 10 faults (with details of time they occurred relevant to parameter Ht) and burner operation hours (Hb).

The History datum item H1 represents the most recent fault that occurred, whereas the History datum item H10 represents the least recent. The codes of the faults saved are also displayed in the corresponding menu of the Opentherm remote control.

Note for calculation of hours:

- Every 24 hours, the number shown in the part of the display normally reserved for system pressure is increased by one unit.
- Every hour, the number shown in the part of the display normally reserved for room temperature is increased by one unit.

Press the Heating buttons to scroll the list of faults.

Ht	Total hours with card fed.
H1	Fault code --> Time fault occurred (relevant to Ht)
H2	Fault code --> Time fault occurred (relevant to Ht)
H3	Fault code --> Time fault occurred (relevant to Ht)
H4	Fault code --> Time fault occurred (relevant to Ht)
H5	Fault code --> Time fault occurred (relevant to Ht)
H6	Fault code --> Time fault occurred (relevant to Ht)
H7	Fault code --> Time fault occurred (relevant to Ht)
H8	Fault code --> Time fault occurred (relevant to Ht)
H9	Fault code --> Time fault occurred (relevant to Ht)
H10	Fault code --> Time fault occurred (relevant to Ht)
Hb	Hours of burner operation.

Press the Reset button to return to the Service Menu. Press the Reset button for 10 seconds to exit to the card Service Menu.

"rE" - History Reset

Press the Eco/comfort button for 3 seconds to delete all the faults and the hours stored in the History Menu: the card will automatically exit the Service Menu, in order to confirm the operation.

Press the Reset button to return to the Service Menu.

4.2 Commissioning



Checks to be made at first lighting, and after all maintenance operations involving disconnection from the systems or an operation on safety devices or parts of the boiler:

Before lighting the boiler

- Open any on-off valves between the boiler and the systems.
- Check the tightness of the fuel system.
- Check the pre-filling of the expansion tank
- Fill the water system and make sure that all air contained in the boiler and the system has been vented by opening the air vent valve on the boiler and any vent valves on the system.
- Make sure there are no water leaks in the system, hot water circuits, connections or boiler.
- Make sure the electrical system is properly connected and the earth system works properly.
- Make sure there are no flammable liquids or materials in the immediate vicinity of the boiler.
- Fit the pressure gauge and the vacuum gauge on the pump (remove after starting) of the burner.
- open the gate valves along the diesel pipe

Start-up

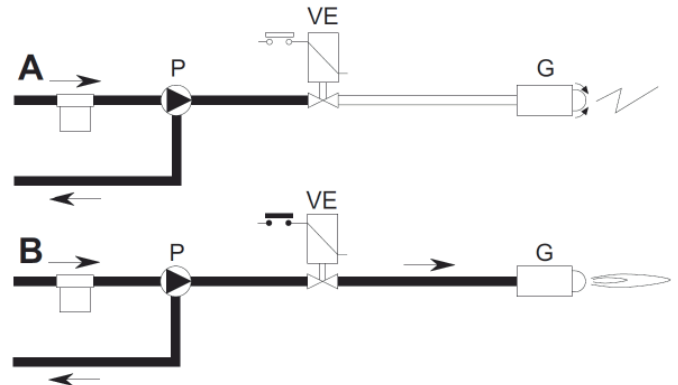

fig.30 - Starting

A

When the thermostatic line closes, the burner motor starts turning together with the pump: all the oil sucked is sent to the return. The burner blower and the ignition transformer are also working, therefore the following stages are carried out:

- firebox prevention.
- prewash of a part of the oil circuit.
- preignition, with discharge between electrode tips.

B

At the end of prewash, the unit opens the electromagnetic valve: the oil reaches the nozzle, where it is finely sprayed.

Its contact with the discharge between the electrode tips creates the flame.

The safety time begins simultaneously.

Unit cycle

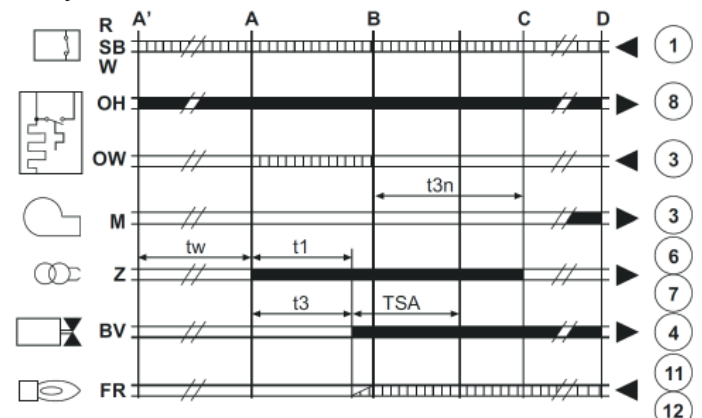



fig.31 - Unit cycle

- R-SB-W Thermostats/Pressure switches
- OH Oil pre-heater
- OW Operation enabling contact
- M Burner motor
- Z Ignition transformer
- BV Electromagnetic valve
- FR Photoresistance
- A' Starting with pre-heater

A	Starting without pre-heater
B	Flame present
C	Normal operation
D	Adjustment stop (TA-TC)
t1	Pre-ventilation time
TSA	Safety time
t3	Pre-ignition time
t3n	Post-ignition time
tw	Pre-heating time
	Output signals from the unit
	Necessary input signals

Checks during operation

- Ignite the appliance as described in sec.2.3.
- Check that the fuel circuit and water systems are airtight.
- Check the efficiency of the flue and air-fume ducts while the boiler is working.
- Check that the water is circulating properly between the boiler and the systems.
- Check the proper ignition of the boiler by performing various tests, turning it on and off with the room thermostat or remote control.
- Check that the burner door and fume chamber are tight.
- Check that the burner works properly.
- Analyse the combustion (with the boiler unit stable) and check that the content of CO₂ in the fumes is between 11% and 12%.
- Check the parameters are programmed correctly and perform any required customization (compensation curve, power, temperatures, etc.).

4.3 Maintenance

Periodical check

To ensure correct operation of the unit over time, have qualified personnel carry out a yearly check, providing for the following:

- The control and safety devices must function correctly.
- The fume exhaust circuit must be perfectly efficient.
- Check there are no obstructions or dents in the fuel supply and return pipes. - Clean the filter of the fuel suction line.
- Measure the correct fuel consumption
- Clean the combustion head in the fuel outlet zone, on the swirl disc.
- Leave the burner running at full rate for approximately ten minutes, then analyse the combustion, checking:
 - All the elements specified in this manual are set correctly
 - Temperatures of the fumes at the flue
 - CO₂ percentage content
- The air-fume end piece and ducts must be free of obstructions and leaks
- The burner and exchanger must be clean and free of deposits. For possible cleaning do not use chemical products or wire brushes.
- The gas and water systems must be airtight.
- The water pressure in the cold water system must be approx. 1 bar; otherwise, bring it to that value. • The circulating pump must not be blocked.
- The expansion tank must be filled.
- Check the magnesium anode and replace it if necessary.

 The boiler casing, control panel and aesthetic parts can be cleaned with a soft damp cloth, if necessary soaked in soapy water. Do not use any abrasive detergents and solvents.

Cleaning the boiler

1. Disconnect the power supply to the boiler.
2. Remove the upper panel "A" and open the burner door.
3. Unscrew the nuts "B".
4. Remove the cover from the smoke chamber "E".
5. Remove the turbulators "C".
6. Wipe the outlet of the fumes with a brush "D" and an aspirator.
7. Remove all residues from the combustion chamber.
8. Reassemble all removed components.

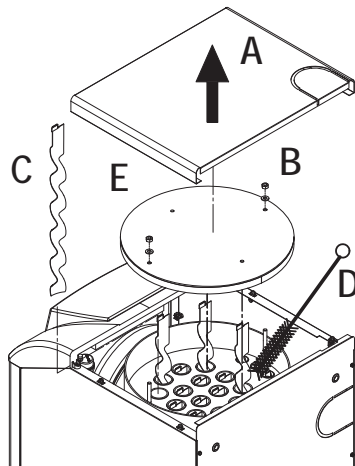

fig.32

Accessing the electrode and nozzle

- Disconnect the transformer electrode cables and remove the photoresistance 1, and the union 2 connecting the oil pipe to line 3 of the nozzle. Loosen the screws 4 and pull out the nozzle-baffle-electrode flange assembly.

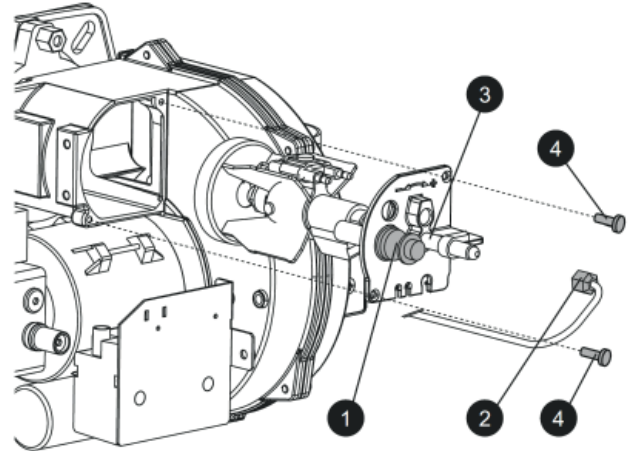

fig.33

- Undo the screw 5 to remove the baffle and screw 6 to remove the electrodes. Proper cleaning of the nozzle is obtained by removing the filter and cleaning the slots and spraying hole with petrol, rinsing it with fuel oil. When reassembling everything, pay attention to the correct positioning of the electrodes-baffle.

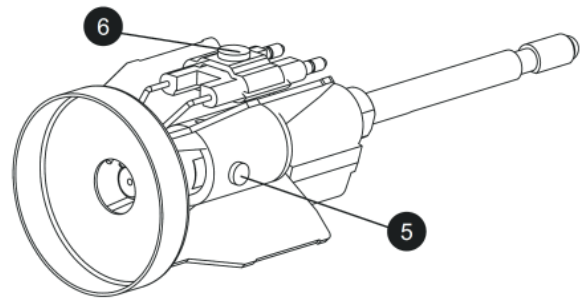

fig.34

Condensate tank

To access the condensate tank, open the lower cover (Fig. 35).

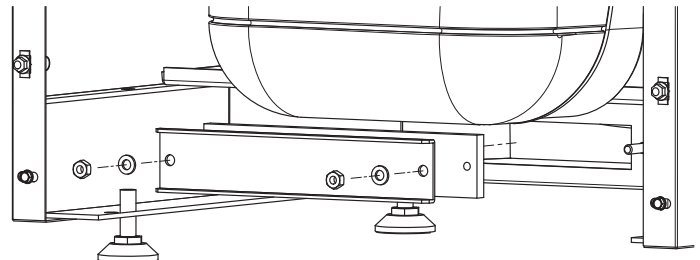

fig.35

4.4 Troubleshooting

Diagnostics

The boiler is equipped with an advanced self-diagnosis system. In case of a boiler fault, the display will flash together with the fault symbol (9 - fig.1) indicating the fault code.

There are faults the cause permanent shutdowns (marked with the letter "A"): to restore operation, just press the **RESET** button (3 - fig.1) for 1 second or use the **RESET** on the remote timer control (optional) if installed; if the boiler does not restart, it is necessary to eliminate the fault indicated in the operation LEDs.

Other faults cause temporary shutdowns (marked with the letter "F") which are automatically reset as soon as the value returns within the boiler's normal working range.

Circulating pump

Faults must only be repaired by qualified specialist technicians, work on electrical connections must only be carried out by qualified specialist electricians.

Faults	Causes	Cures
Pump not working with power switched on	Faulty electrical fuse	Check fuses
	No power to pump	Eliminate the power supply interruption
Noisy pump	Cavitation due to insufficient delivery pressure	Increase the system pressure within the permissible range
		Check the head setting and set a lower head if necessary
The building does not get warm	Radiant panel thermal power too low	Increase the delivery value
		Set the adjustment mode to $\Delta p-c$ instead of $\Delta p-v$

Fault signals

- The fault LED signals a fault.
- The pump stops (depending on the fault), and makes cyclical attempts to restart

LED	Faults	Causes	Cures
Lights up red	Fault	Blocked rotor	Activate manual restart or contact Customer Service
	Contact/winding	Faulty winding	
Flashes red	Under/overvoltage	Supply side voltage too low/high	Check the mains voltage and conditions of use. Request Customer Service
		Excessive module temperature	
	Short circuit	Motor current too high	
Flashing red/green	Turbine operation	The hydraulic system of the pumps is fed, but the pump has no mains voltage	Check the mains voltage, flow rate/water pressure and also the ambient conditions
		Dry running	
	Overload	The motor turns with difficulty. Pump not running according to specifications (e.g. high module temperature). The speed is lower than in normal operation.x	

Table. 3 - List of faults

Fault code	Fault	Possible cause	Cure
A01	Bloqueo del quemador	Pump blocked	Replace
		Faulty electric motor	Replace
		Faulty oil valve	Replace
		No fuel in tank, or water on bottom	Refill with fuel or suck the water
		Oil line feed valves closed	Open
		Dirty filters (line-pump-nozzle)	Clean
		Pump unprimed	Prime and find the cause of unpriming
		Ignition electrodes not properly adjusted, or dirty	Adjust or clean them
		Nozzle clogged, dirty or deformed	Replace
		Unsuitable head and shutter adjustments	Adjust
		Faulty electrodes or earthed	Replace
		Faulty ignition transformer	Replace
		Faulty electrode wires or earthed	Replace
		Electrode wires deformed by high temperature	Replace and protect
		Faulty valve or transformer electrical connections	Check
A02	Flame present signal with burner off	Broken pump-motor joint	Replace
		Pump inlet connected to return pipe	Correct the connection
A03	Overtemperature protection activation	Faulty photoresistance	Replace
		Dirty photoresistance	Clean the photoresistance
		Photoresistance short circuit	Replace the photoresistance
A04	Card parameter fault	Extraneous light strikes the photoresistance	Eliminate the light source
		Wrong card parameter setting	Check the card parameter and modify it if necessary
F07	Preheater fault (the contact does not close in 120 seconds)	Heating sensor damaged	Check the correct positioning and operation of the heating sensor
		No water circulation in the system	Check the circulating pump.
		Air in the system	Vent the system
A09	Card parameter fault	Wrong card parameter setting	Check the card parameter and modify it if necessary
F10	Delivery sensor 1 fault	Preheater failure	Check the preheater
		Wiring disconnected	Check the wiring
		Sensor damaged	Check the wiring or replace the sensor
Wiring shorted			
F11	DHW sensor fault	Wiring disconnected	Check the wiring or replace the sensor
		Sensor damaged	
		Wiring shorted	
F12	Card parameter fault	Wrong card parameter setting	Check the card parameter and modify it if necessary
		Wrong card parameter setting	
F14	Delivery sensor 2 fault	Wrong card parameter setting	Check the wiring or replace the sensor
		Sensor damaged	
		Wiring shorted	
F16	Card parameter fault	Wiring disconnected	Check the card parameter and modify it if necessary
		Wrong card parameter setting	
F34	Supply voltage under 170V.	Electric mains trouble	Check the electrical system

Fault code	Fault	Possible cause	Cure
F35	Faulty mains frequency	Electric mains trouble	Check the electrical system
F37	Incorrect system water pressure	Pressure too low Sensor damaged	Fill the system Check the sensor
F39	External probe fault	Probe damaged or wiring shorted Probe disconnected after activating the sliding temperature	Check the wiring or replace the sensor Reconnect the external sensor or disable the sliding temperature
F40	Incorrect system water pressure	Pressure too high	Check the system Check the safety valve Check the expansion vessel
A41	Sensor positioning	Delivery sensor not inserted in boiler shell	Check the correct positioning and operation of the heating sensor
F42	Heating sensor fault	Sensor damaged	Replace the sensor
F47	System water pressure sensor fault	Wiring disconnected	Check the wiring

5. TECHNICAL DATA AND CHARACTERISTICS

5.1 Main components, dimensions and connections

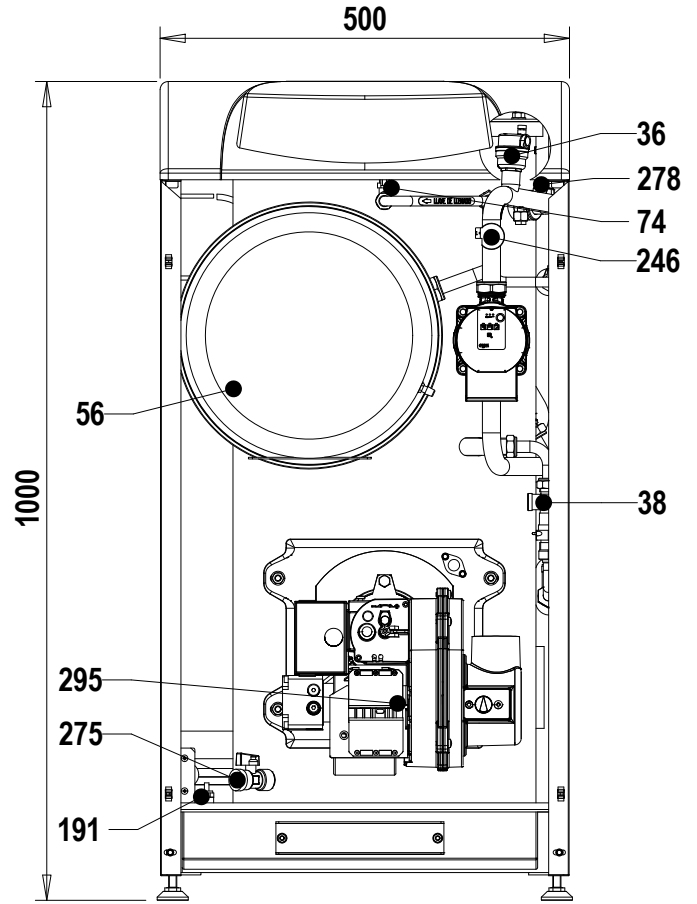

fig.37 - Front view

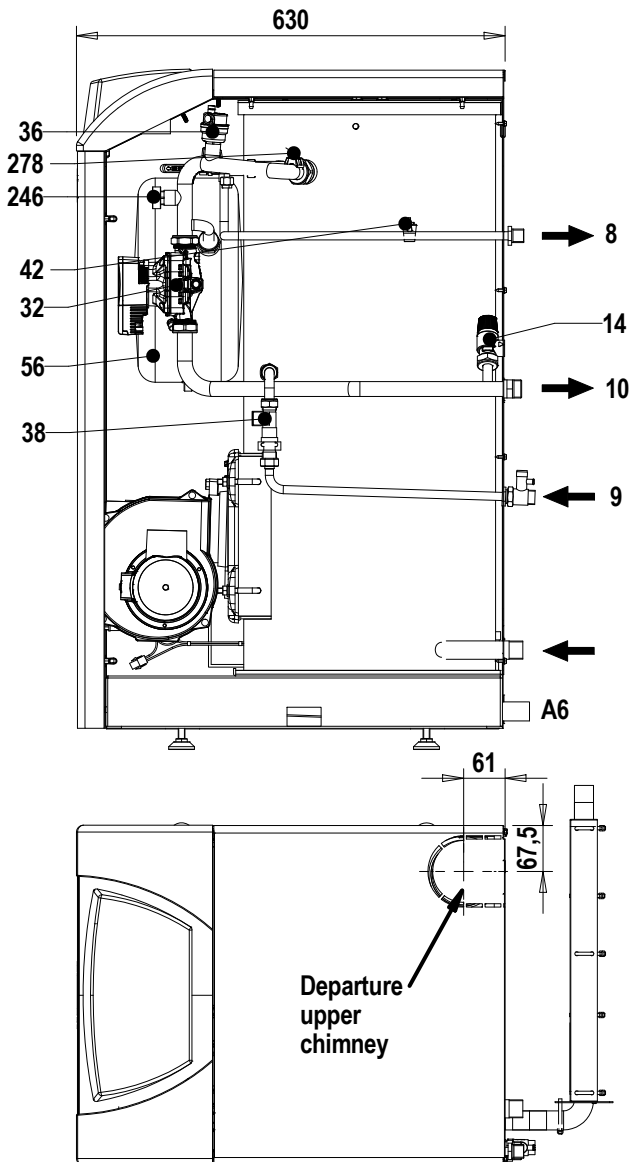

fig.36 - Side and top view

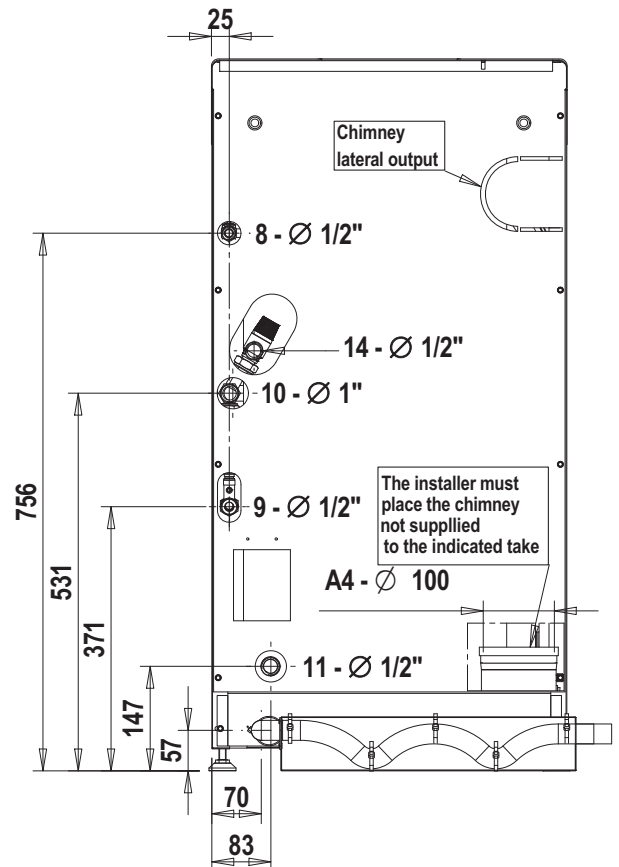

fig.38 - Rear view

KYRA D 30 SI UNIT COND

5.2 Water circuit

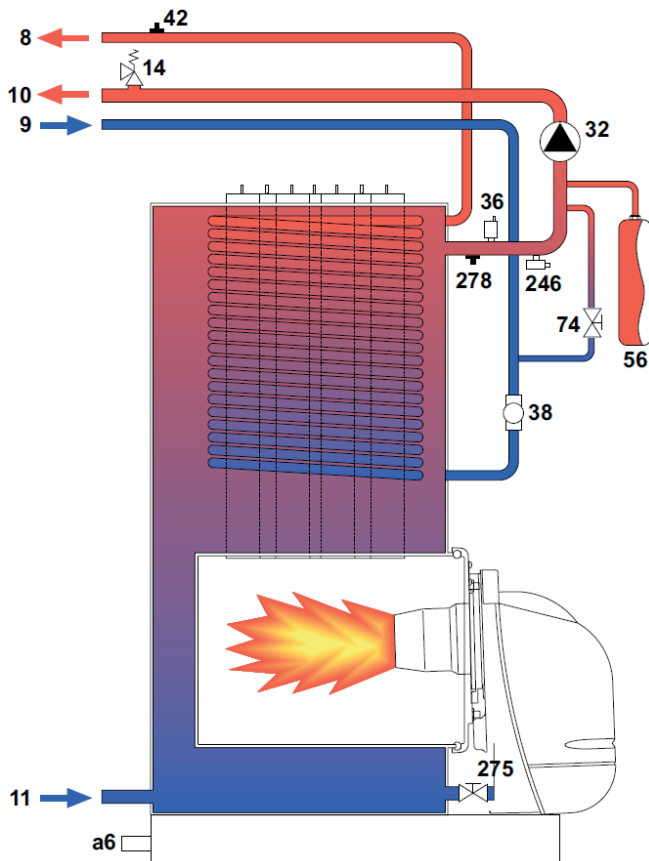

fig.39 - Water circuit

Legend of the figures chapter 5

- A4 = Smoke outlet Ø 100
- A6 = Condensate discharge
- 8 = DHW outlet Ø 1/2"
- 9 = DHW input Ø 1/2"
- 10 = System delivery Ø 3/4"
- 11 = System return Ø 3/4"
- 14 = Safety valve Ø 1/2"
- 32 = Heating circulating pump
- 36 = Automatic air vent
- 38 = Flow switch
- 42 = DHW temperature sensor (optional)
- 56 = Expansion vessel
- 74 = Charging key
- 191 = Smoke temperature sensor
- 246 = Pressure transducer
- 275 = Key download heating circuit
- 278 = Double sensor (Safety + heating)
- 295 = Burner

5.3 Diagrams

Circulating pumps Head/Pressure loss

- Circulating pump head with setting at "fixed speed".

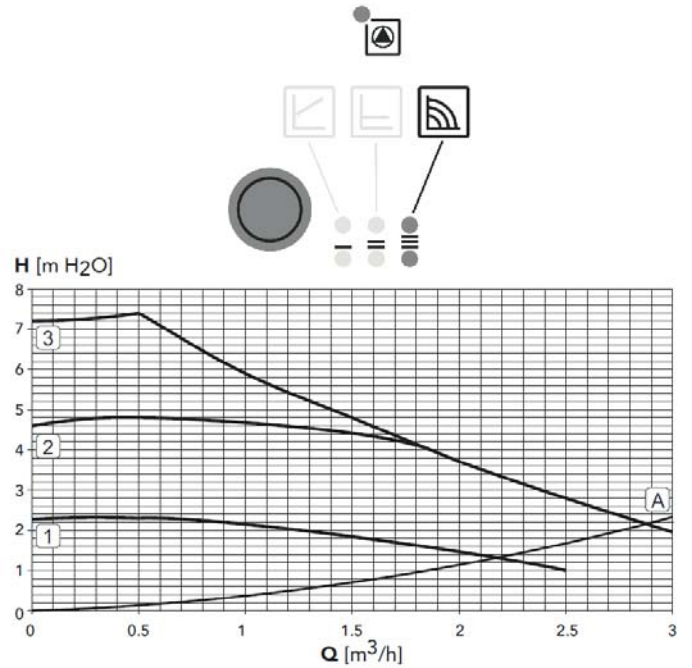

fig.40

- A Boiler pressure losses
- 1 - 2 - 3 Circulating pump speed

- Circulating pump head with setting at "proportional head".

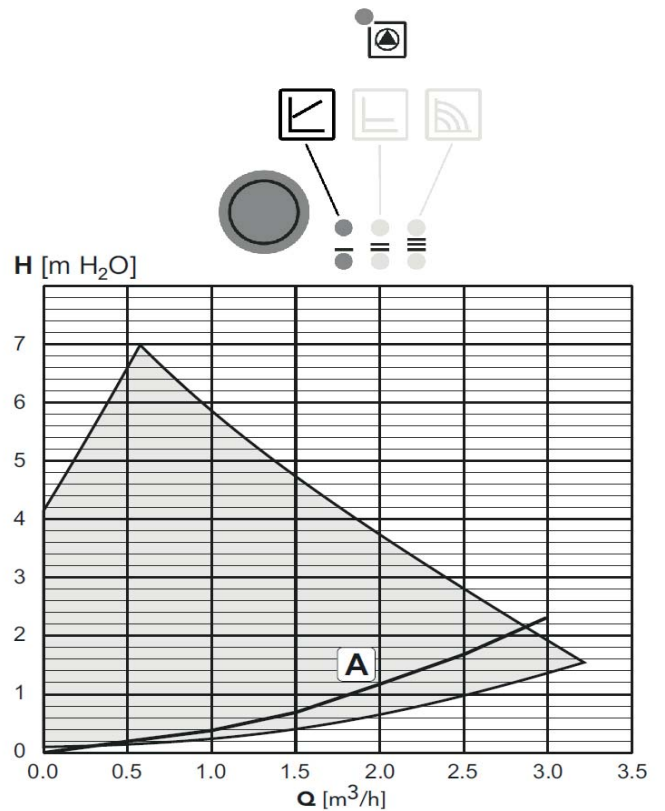

fig.41

- A Boiler pressure losses

5.4 Technical data table

Model	KYRA D 30 SI UNIT COND		
Max. heating capacity	kW	29,3	(Q)
Min. heating capacity	kW	16,0	(Q)
Max. heat output in heating (80/60)	kW	28,5	(P)
Min. heat output in heating (80/60)	kW	15,6	(P)
Max. heat output in heating (50/30)	kW	30,0	(P)
Min. heat output in heating (50/30)	kW	16,6	(P)
Efficiency Pmax (80-60°C)	%	97,0	
Efficiency Pmin (80-60°C)	%	97,6	
Efficiency Pmax (50-30°C)	%	102,3	
Efficiency Pmin (50-30°C)	%	105,5	
Efficiency 30%	%	103,7	
Efficiency class according to directive 92/42 CE		★ ★ ★ ★	
Max. working pressure in heating	bar	3	(PMS)
Min. working pressure in heating	bar	0,8	
Max. heating temperature	°C	80	(tmáx)
Heating water content	liters	49	
Heating expansion tank capacity	liters	10	
Heating expansion tank prefilling pressure	bar	1	
Max. working pressure in DHW	bar	6	(PMW)
Min. working pressure in DHW	bar	0,3	
Content of the DHW circuit	liters	1,7	
DHW flow rate Δt 25 °C	l/min	17,2	
DHW flow rate Δt 30°C	l/min	14,3	
Protection rating	IP	X0D	
Power supply voltage	V/Hz	230/50	
Electrical power input	W	320	
Empty weight	kg	115	
Combustion chamber length	mm	280	
Combustion chamber diameter	mm	220	
Pressure losses, fume side	mbar	0,35	

ErP product fiche

MODEL: KYRA D 30 SI UNIT COND

Trademark: LAMBORGHINI			
Condensing boiler: SÍ			
Low-temperature boiler (**): NO			
B1 Boiler: NO			
Combination heater: SÍ			
Cogeneration space heater: NO			
Item	Symbol	Unit	Value
Seasonal space heating energy efficiency class (from A++ to G)			
Seasonal space heating energy efficiency class (from A++ to G)			A
Rated heat output	Pn	kW	29
Seasonal space heating energy efficiency	η_s	%	91
Useful heat output			
Useful heat output at rated heat output and high-temperature regime (*)	P4	kW	28,5
Useful heat output at 30% of rated heat output and low-temperature regime (**)	P1	kW	6,6
Useful efficiency			
Useful heat output at rated heat output and high-temperature regime (*)	η_4	%	91,0
Useful heat output at 30% of rated heat output and low-temperature regime (**)	η_1	%	97,5
Auxiliary electricity consumption			
At full load	elmax	kW	0,188
At part load	elmin	kW	0,075
In standby mode	PSB	kW	0,003
Other items			
Standby heat loss	Pstby	kW	0,100
Ignition burner power consumption	Pign	kW	0,000
Annual energy consumption	QHE	GJ	70
Sound power level	LWA	dB	66
Emissions of nitrogen oxides	NOx	mg/kWh	86
For combination heaters			
Declared load profile			XL
Water heating energy efficiency class (from A to G)			A
Daily electricity consumption	Qelec	kWh	0,250
Annual electricity consumption	AEC	kWh	55
Water heating energy efficiency	η_{wh}	%	81
Daily fuel consumption	Qfuel	kWh	24,158
Annual fuel consumption	AFC	GJ	19

(*) High-temperature regime means 60°C return temperature at heater inlet and 80°C feed temperature at heater outlet.

(**) Low temperature means for condensing boilers 30°C, for low-temperature boilers 37°C and for other heaters 50°C return temperature (at heater inlet).

5.5 Wiring diagram

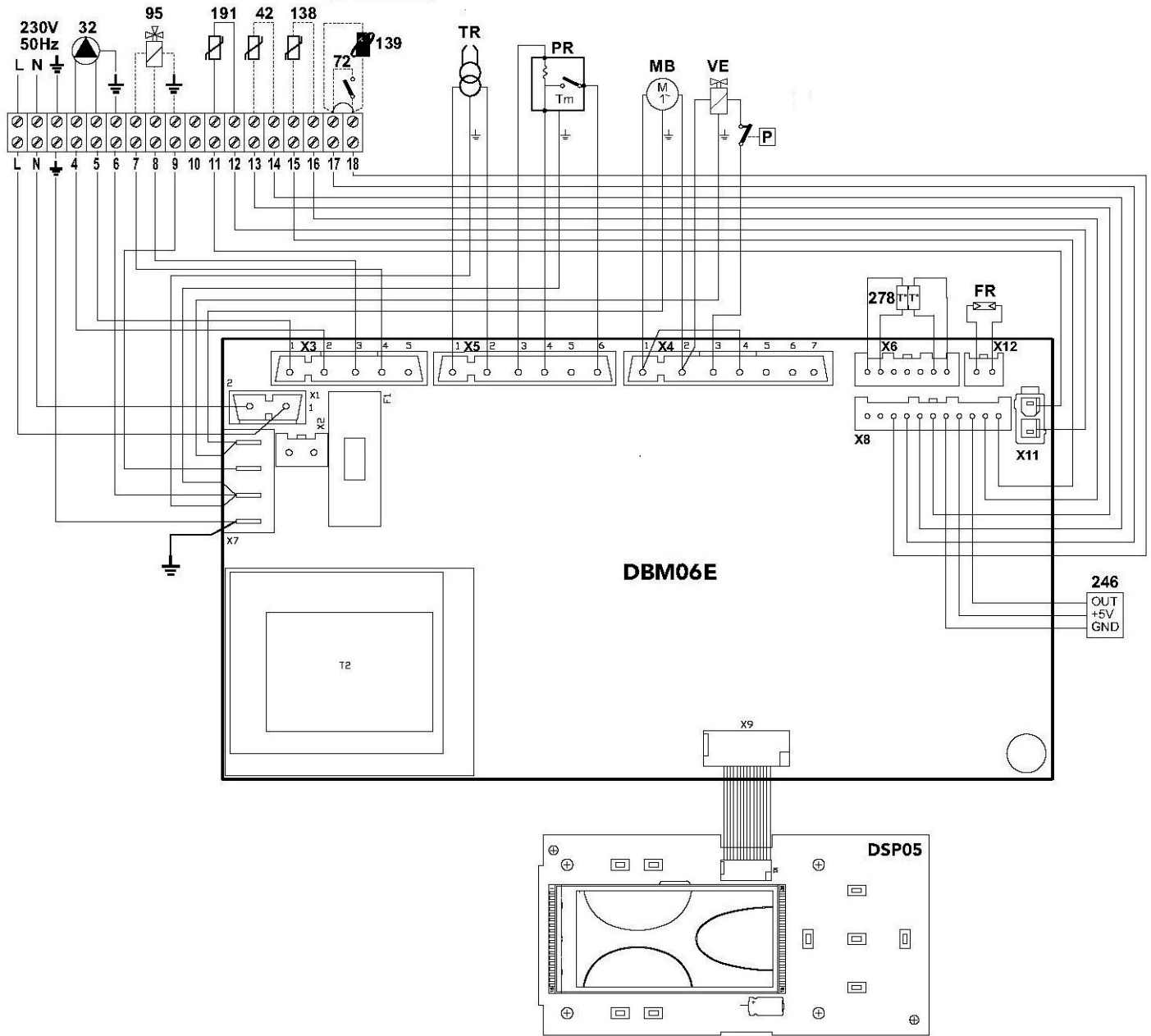

fig.42 - Wiring diagram

- 32 Heating circulating pump
- 38 Flow switch
- 42 DHW temperature sensor (optional)
- 72 Room thermostat (optional)
- 138 External probe (optional)
- 139 Remote Timer Control (optional)
- 191 Smoke temperature sensor
- 246 Pressure transducer
- 278 Double sensor (Safety + Heating)

- TR Ignition transformer
- PR Preheater
- FR Photoresistance
- MB Burner motor
- VE Electromagnetic valve

Архангельск (8182)63-90-72
 Астана (7172)727-132
 Астрахань (8512)99-46-04
 Барнаул (3852)73-04-60
 Белгород (4722)40-23-64
 Брянск (4832)59-03-52
 Владивосток (423)249-28-31
 Волгоград (844)278-03-48
 Вологда (8172)26-41-59
 Воронеж (473)204-51-73
 Екатеринбург (343)384-55-89
 Иваново (4932)77-34-06

Ижевск (3412)26-03-58
 Иркутск (395)279-98-46
 Казань (843)206-01-48
 Калининград (4012)72-03-81
 Калуга (4842)92-23-67
 Кемерово (3842)65-04-62
 Киров (8332)68-02-04
 Краснодар (861)203-40-90
 Красноярск (391)204-63-61
 Курск (4712)77-13-04
 Липецк (4742)52-20-81

Магнитогорск (3519)55-03-13
 Москва (495)268-04-70
 Мурманск (8152)59-64-93
 Набережные Челны (8552)20-53-41
 Нижний Новгород (831)429-08-12
 Новокузнецк (3843)20-46-81
 Новосибирск (383)227-86-73
 Омск (3812)21-46-40
 Орел (4862)44-53-42
 Оренбург (3532)37-68-04
 Пенза (8412)22-31-16

Пермь (342)205-81-47
 Ростов-на-Дону (863)308-18-15
 Рязань (4912)46-61-64
 Самара (846)206-03-16
 Санкт-Петербург (812)309-46-40
 Саратов (845)249-38-78
 Севастополь (8692)22-31-93
 Симферополь (3652)67-13-56
 Смоленск (4812)29-41-54
 Сочи (862)225-72-31
 Ставрополь (8652)20-65-13

Сургут (3462)77-98-35
 Тверь (4822)63-31-35
 Томск (3822)98-41-53
 Тула (4872)74-02-29
 Тюмень (3452)66-21-18
 Ульяновск (8422)24-23-59
 Уфа (347)229-48-12
 Хабаровск (4212)92-98-04
 Челябинск (351)202-03-61
 Череповец (8202)49-02-64
 Ярославль (4852)69-52-93

Киргизия (996)312-96-26-47

Россия (495)268-04-70

Казахстан (772)734-952-31