

Архангельск (8182)63-90-72
Астана (7172)727-132
Астрахань (8512)99-46-04
Барнаул (3852)73-04-60
Белгород (4722)40-23-64
Брянск (4832)59-03-52
Владивосток (423)249-28-31
Волгоград (844)278-03-48
Вологда (8172)26-41-59
Воронеж (473)204-51-73
Екатеринбург (343)384-55-89
Иваново (4932)77-34-06

Ижевск (3412)26-03-58
Иркутск (395)279-98-46
Казань (843)206-01-48
Калининград (4012)72-03-81
Калуга (4842)92-23-67
Кемерово (3842)65-04-62
Киров (8332)68-02-04
Краснодар (861)203-40-90
Красноярск (391)204-63-61
Курск (4712)77-13-04
Липецк (4742)52-20-81

Магнитогорск (3519)55-03-13
Москва (495)268-04-70
Мурманск (8152)59-64-93
Набережные Челны (8552)20-53-41
Нижний Новгород (831)429-08-12
Новокузнецк (3843)20-46-81
Новосибирск (383)227-86-73
Омск (3812)21-46-40
Орел (4862)44-53-42
Оренбург (3532)37-68-04
Пенза (8412)22-31-16

Пермь (342)205-81-47
Ростов-на-Дону (863)308-18-15
Рязань (4912)46-61-64
Самара (846)206-03-16
Санкт-Петербург (812)309-46-40
Саратов (845)249-38-78
Севастополь (8692)22-31-93
Симферополь (3652)67-13-56
Смоленск (4812)29-41-54
Сочи (862)225-72-31
Ставрополь (8652)20-65-13

Сургут (3462)77-98-35
Тверь (4822)63-31-35
Томск (3822)98-41-53
Тула (4872)74-02-29
Тюмень (3452)66-21-18
Ульяновск (8422)24-23-59
Уфа (347)229-48-12
Хабаровск (4212)92-98-04
Челябинск (351)202-03-61
Череповец (8202)49-02-64
Ярославль (4852)69-52-93

Киргизия (996)312-96-26-47

Россия (495)268-04-70

Казахстан (772)734-952-31

<https://lamborghini.nt-rt.ru/> || hgc@nt-rt.ru

iXwater H-1 P - 1 B

BOLLITORI – TANKS – SPEICHER – BALLONS

200 - 300 - 500 - 800



EN

INSTRUCTION FOR INSTALLATION AND MAINTENANCE

I Il presente manuale è parte integrante del serbatoio e deve essere consegnato all'installatore/utilizzatore insieme ad esso. Il manuale deve essere conservato in luogo sicuro nei pressi del serbatoio. In caso di trasferimento o vendita del serbatoio, il presente manuale d'uso ed installazione dovrà essere trasferito insieme ad esso. L'utilizzatore e l'installatore sono tenuti a leggere attentamente il presente manuale al fine di rispettare le indicazioni tecniche per la sicurezza la corretta messa in funzione dell'apparecchio. La mancata osservanza delle indicazioni di seguito riportate farà decadere tutti i diritti di garanzia legale e contrattuale. L'installazione, la messa in esercizio, la manutenzione e la disattivazione dell'apparecchiatura deve essere eseguita da tecnico qualificato abilitato alla professione. Una corretta installazione e periodici interventi di manutenzione garantiscono una lunga durata al bollitore.

ENG This manual is an integral part of the tank and must be delivered to the installer / user together with it. The manual must be kept in a safe place near the tank. In case of transfer or sale of the tank, this user and installation manual must be transferred together with it. The user and the installer are required to read this manual carefully in order to comply with the technical instructions for safety and correct operation of the appliance. Failure to comply with the instructions below will invalidate all legal and contractual warranty rights. The installation, commissioning, maintenance and deactivation of the equipment must be performed by a qualified technician qualified for the profession. Correct installation and periodic maintenance interventions guarantee a long life for the storage tank.

D Diese Anleitung ist ein integraler Bestandteil des Tanks und sollte dem Installateur / Benutzer zusammen mit diesem übergeben werden. Das Handbuch sollte an einem sicheren Ort in der Nähe des Tanks aufbewahrt werden. Im Falle der Übertragung oder des Verkaufs des Behälters ist diese Bedienungsanleitung und installationshinweise zusammen mit ihm zu übertragen. Benutzer und Installateur sind verpflichtet, diese Anleitung sorgfältig zu lesen, um die technischen Sicherheitshinweise für die korrekte Inbetriebnahme des Geräts einzuhalten. Wenn die nachstehenden Angaben nicht eingehalten werden, werden alle gesetzlichen und vertraglichen Garantierechte erlischt. Die Installation, Inbetriebnahme, Wartung und Außerbetriebnahme des Geräts muss von einem qualifizierten Techniker durchgeführt werden, der dazu befähigt ist. Eine korrekte Installation und regelmäßige Wartungsarbeiten garantieren eine lange Lebensdauer des Kessels.

FR Ce manuel fait partie intégrante du ballon et doit être donné à l'installateur/utilisateur avec celui-ci. Le manuel doit être conservé en lieu sûr près du ballon. En cas de transfert ou de vente du ballon, ce manuel d'utilisation et d'installation doit être transféré avec lui. L'utilisateur et l'installateur sont tenus à lire attentivement ce manuel afin de respecter les indications techniques de sécurité et la bonne mise en service de l'appareil. Le non-respect des indications ci-dessus fera expirer tous les droits de garantie légale et contractuelle. L'installation, la mise en service, la manutention et la désactivation de l'équipement doivent être effectués par un technicien qualifié. Une installation correcte et la manutention périodique garantissent une longue durée de vie au ballon.

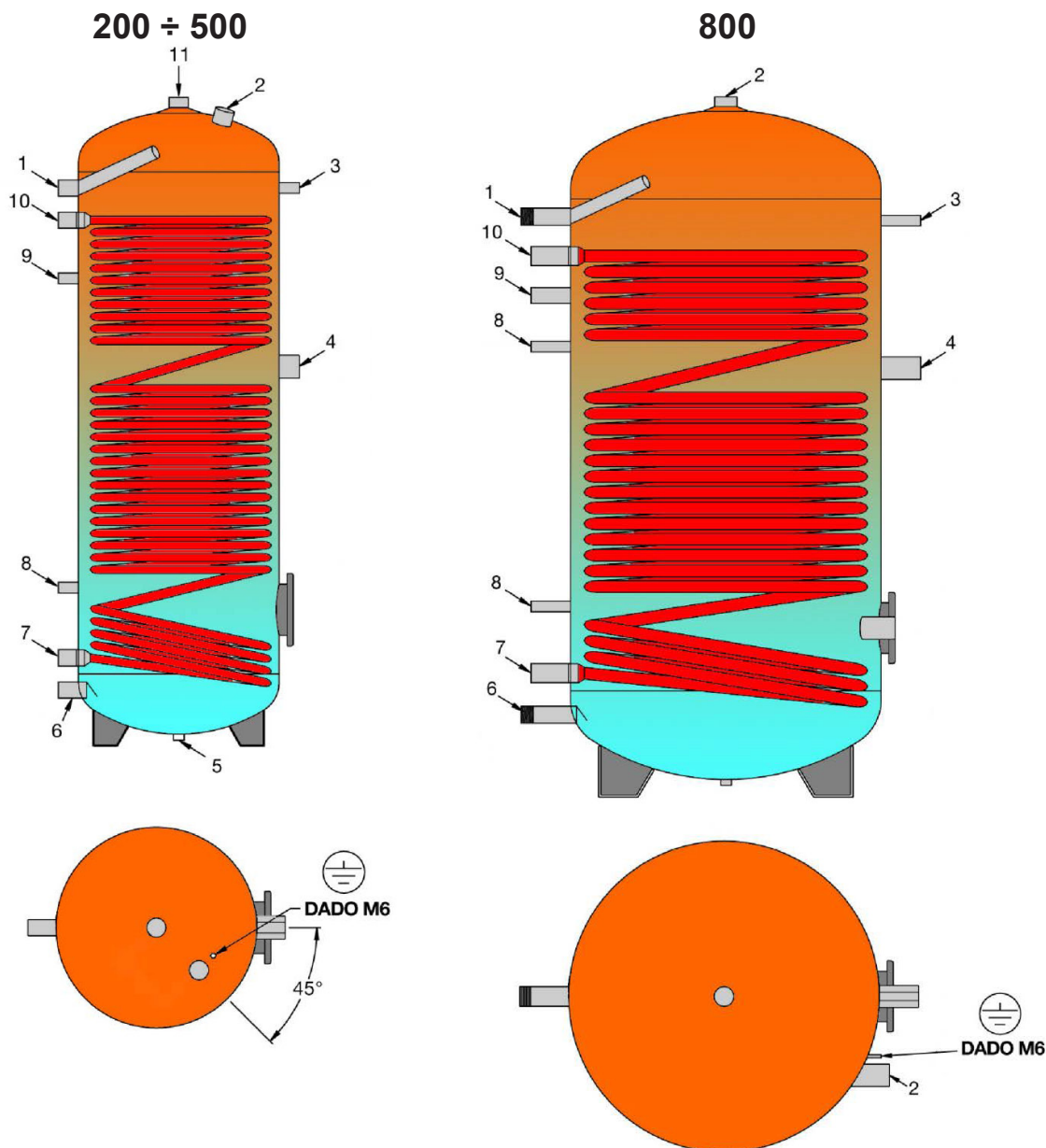

MODELLO / MODEL MODEL / MODÉLE		200÷500	800
1	Mandata acqua calda	1"1/4	1"1/4
	Domestic hot water inlet		
	Brauchwarmwasser-Entnahme		
	Entree eau chaude		
2	Anodo	1" 1/4	1" 1/4
	Anode		
	Anode		
	Anode		
3	Termometro - Sonda	1/2"	1/2"
	Thermometer - Feeler		
	Thermometre - Sonde		
4	Resistenza elettrica	1" 1/2	1" 1/2
	Electric heater		
	Elektro -Heizstab		
5	Attacco bancale (cieco)	1/2"	-
	Blind connection for fasting		
	Blindmuffe zur Befestigung		
	Fixage ballon		

6	Entrata acqua fredda	1"	1"1/4
	Cold water inlet		
	Kaltwasser - Vorlauf		
	Sortie eau froide		
	Ritorno serpentino		
7	Water exchanger outlet	1"	1"1/4
	Wärmetauscher Rücklauf		
	Sortie serpentin eau froide		
8	Sonda	1/2"	1/2"
	Feeler		
	Fühler		
9	Ricircolo	1/2"	1"
	Re-circulation		
	Zirkulation		
10	Retour eau chaude	1"	1"1/4
	Mandata serpentino		
	Water exchanger inlet		
	Wärmetauscher Vorlauf		
	Entree serpentin eau chaude		

ENG

INSTALLATION INSTRUCTIONS, COMMISSIONING AND MAINTENANCE

What follows is determinant for the warranty validity.

1. The installation and commissioning must:
 - Be executed by a qualified installer.
 - Be provided, where necessary, with a pressure water reducing in entrance.
 - Be provided with a safety valve according to the technical datas of the boiler.
 - Provide expansion vessels connected at a maximum distance of one meter from the tank (see the measuring board of the expansion vessel) proportioned to the boiler's dimensions (the size shall be checked by an expert).
 - Provide washing of the lines before commissioning, any impurities or processing chips present in the hydraulic system can cause corrosion and permanently contaminate the tank.
 - Be provided with filters upstream of the tank to avoid the deposit of heavy particles or processing residues inside the tank.
2. Before starting, check the hydraulic seal of the connections and hatches. Apply a torque of 20 Nm for handhole hatches and 40 Nm for manhole to the hatch screws. If some leakage occurs check the assembly of the expansion vessels.
3. Install the boiler in a technical room providing suitable drainage in case of possible liquid leaks from the tank.
4. Do not switch on any heat source connected to the tank until it is guaranteed to fill it completely.
5. In case of use on the system of materials other than those of the tank, provide for the dielectrical insulation of the different parts. The equipotential ground connection must be made both for the tank and for the pipes connected to it and must be suitably checked in compliance with the regulations in force.
6. Make sure and arrange that, for the purpose of preventing contamination of the domestic water and altering the anti-freezing mixture of the solar circuits, the pressure of the exchanger is always lower than the pressure of the accumulation, also through automatic control of the differential pressure between the circuits primary and secondary.
7. In case of danger of freezing, the tank and the exchanger must be heated or completely emptied. Even if the tank is not used for a long time, empty the tank, in fact the prolonged stagnation of water in the tank favors internal corrosion and the proliferation of bacteria and microorganisms.
8. The temperature of the boiler inside must always be under 95°C (70°/80°C for the SMALVER/SMALTECH models).
9. In order to avoid corrosion, the anodes must be inspected after each 12 months. However, where the water is particularly aggressive, the inspections must be done each 6 months; if the anode diameter in any section is less than 22 mm, it must be replaced, if covered with limestone is to be cleaned.
10. The water Langelier Index at the operating temperature, must range from "0" to "+0,4", hardness within 10°F and 20°F, maximum concentration of chlorides 70 mg/l, minimum conductivity 150 microS/cm.

DIMENSIONAMENTO VASO D'ESPANSIONE:

Negli impianti con anelli di ricircolo sanitari, si deve considerare anche il volume d'acqua presente nelle tubature.

DIMENSIONING OF THE EXPANSION TANK:

In equipments with sanitary re-circulation rings the volume of the water in the pipes is to be taken into account.

BEMESSUNG DES EXPANSIONSGEFÄß:

In Anlagen mit Wasserzirkulationsringen muss man auch das Wasservolumen der Rohrleitungen berücksichtigen.

DIMENSIONNEMENT DU VAS D'EXPANSION:

Dans les installations avec bagues de cercle sanitaires on doit considérer aussi le volume d'eau dans les tuyauteries.

Tipo Type Typ Typ	Dim. min. vaso esp. Min. size exp. vessel Min. Größe Ausgleichsgefäß Taille min. vase d'exp.	Dim. max. vaso esp. Max. size exp. vessel Max. Größe Ausgleichsgefäß Taille max. vase d'exp.
200	12	18
300	18	25
500	25	50
800	50	80

PRESSIONE MASSIMA DI ESERCIZIO DEL SANITARIO
MAXIMAL WORKING-PRESSURE
MAXIMALER BETRIEBSDRUCK
PRESSION MAXIME D'EXERCICE DU SANITAIRE

8 / 10 bar
PRESSIONE MASSIMA DI ESERCIZIO DELLO SCAMBIATORE
MAXIMAL WORKING PRESSURE HEAT EXCHANGER
MAXIMALER BETRIEBSDRUCK WÄRMETAUSCHER
PRESSION MAXIME D'EXERCICE DU CHANGEUR

10 bar

I serbatoi rispettano i requisiti fondamentali della Direttiva Europea 2014/68/UE relativa alle attrezzature a pressione, in accordo all' art. 4.3.

The tanks are produced according to the basic EEC Directives 2014/68/UE (P.E.D.) for the pressure equipments, as in the art. 4.3.

Die Speicher werden nach den 2014/68/UE (P.E.D.) Europäische Druckgeräte Richtlinien hergestellt, gemäss Artikel 4.3.

Les ballons sont produit selon les exigences fondamentales de la directive européenne 2014/68/UE (P.E.D.) pour les équipements a pression, en accordance a l' article 4.3.

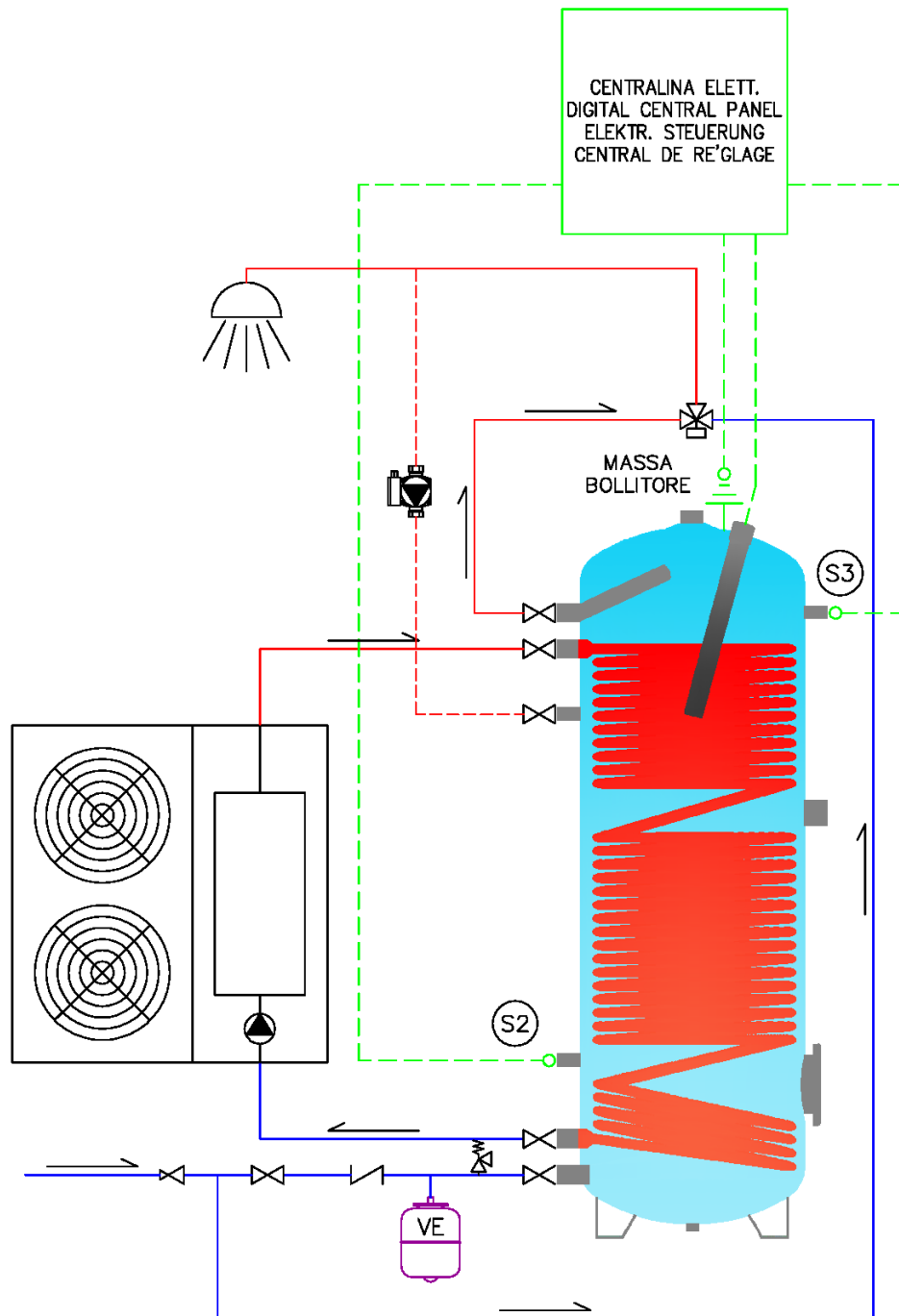

I Esempio di collegamento:

Schema di impianto con pompa di calore, con integrazione pannello solare.

ATTENZIONE: Gli schemi idraulici sono indicativi. La progettazione deve essere eseguita da un professionista abilitato.

ENG Example of connection:

plant schema with heat pump with integration of solar panel.

ATTENTION: the hydraulic schemas are indicative. The design must be realized by a qualified professional.

D Beispiel Schaltschema:

Hydraulische Anlage mit Wärmepumpe und Anbindung an Solarkollektoren.

ACHTUNG: Hydraulische Pläne sind Vorschläge. Die Projektierung muss von einer zugelassenen Fachfirma erfolgen.

FR Exemple de connexion:

Schéma de plante avec pompe a chaleur et intégration panneau solaire.

ATTENTION: Les schémas hydraulique sont indicatifs. Le projet doit être réalisé par un professionnel formé.

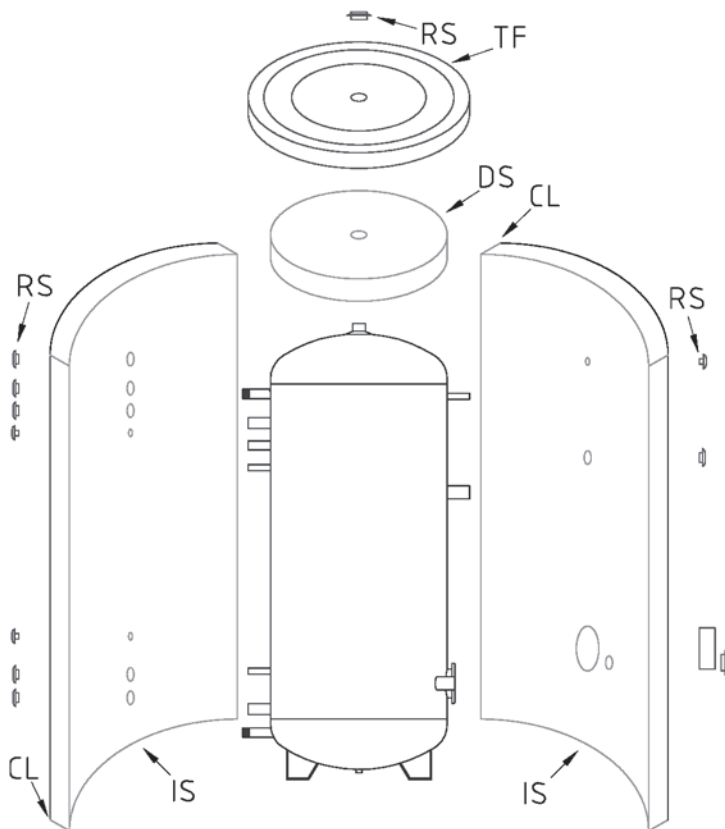

I ISOLAMENTO MORBIDO:

TF = Coperchio superiore

DS = Disco isolamento

IS = Isolamento diviso in 2 o più parti

CL = Cerniera lampo

RS = Rosette di finitura

Assemblaggio:

1. Stendere le due parti dell'isolamento "IS" in modo che i fori dell'isolamento "IS" e i manicotti del boiler coincidano.
2. Fissare l'isolamento "IS" con le rosette "RS" adatte.
3. Chiudere le due cerniere "CL" avendo cura di facilitare la chiusura tenendo vicini i due lembi dell'isolamento "IS" e spingendoli verso il boiler.
4. Inserire il disco isolamento "DS" in modo da pareggiarlo con l'isolamento "IS".
5. Mettere il coperchio "TF" avendo cura di non rovinare l'isolamento "IS".

Attenzione:

I materiali impiegati possono subire deformazioni a causa di oscillazioni di temperature; vi raccomandiamo di conservarli in ambienti coperti ed a temperature miti (15÷20 °C).

ENG SOFT INSULATION:

TF = Plastic upper-cover

DS = Insulation disk (soft polyurethane)

IS = Insulation jacket in two parts

CL = Zip fastener

RS = Plastic washer

Instructions for assembling:

1. The insulation jacket has to be leaned around the cylinder paying attention to coincide the arranged holes with the connections.
2. Put the suitable plastic washer.
3. Close the zip fastener cleaning the 2 parts of the insulation jacket.
4. Put the insulation disk DS on the top.
5. Set up the plastic cover TF with care.

Please to remark:

The insulation jacket consist of materials wich are subjected at dilation or restriction owing to swinging of temperatur – We recommand to keep yhen by temperatur of 15 – 20 °C.

ENG The construction's company guarantees his own products which are supplied with identification code. Claims for faults must happen in 8 days in writing or through the guarantee-card, with the approval by our point of sale. In case of contestations, after our examination of the defect and their causes, the guarantee consists in the repairing by loco or in the substitution of the product, free of freight-charge, upon restitution of the item with manufacturing defect. The installation costs are excluded, except specific agreements.

The guarantee is subjected to the following conditions:

- Claims must happen before the manufacture to complement or assignment to a third party.
- Installation of water-heating must be made from qualified firm/installer, **furthermore the plant has to be equipped with safety valve and suitable expansion-vessel. The points listed in the Installation, Commissioning and Maintenance Instructions must be observed.**
- Water-heaters by Smalglass or Smalver are subjected to use and maintenance as normally required, temperature and pressure working must be strictly observed, examination and replacement of magnesium anode (best every 6 months), Langelier water index between 0 and +0,4, hardness within 10°F and 20°F, maximum concentration of chlorides 70 mg/l, minimum conductivity 150 microS / cm.

From the guarantee are excluded damages due through:

- Faulty montage, making ready for use out of specification or improper use of water-heater.
- Defects caused from no force majeure (impact in case of montage or in building site or by conveyance).
- Intake of parcels, that are rest of material of montage, or damages caused from no controlled and no closed gaskets.
- The carbon steel tanks are supplied externally painted for aesthetic purposes only, any irregularities, cracks or detachment of parts of the paint are not to be attributed to processing defects but are caused by surface alterations due to the high temperature processing of the tanks themselves (enamelling in the oven, pickling, welding, etc.). These superficial aspects in no way affect the duration and functionality of the tank which remains fully guaranteed by the manufacturer. Therefore, requests for replacement or compensation relating to this aspect are not accepted.
- Insulation damage detected after boiler installation.
- Rust or humidity on the threads of the connections are natural phenomena that do not alter the functionality of the same, it will be the installer who, if he deems it appropriate, will be able to clean the threads before making the joints.
- The complaints don't entitle deduction of purchase price or a part of it or for compensation with other requires.

We exercise the right to reject requires of guarantees if buyer doesn't respect the obligation of current payments. Further requires of compensation, in special way for directs and indirect damages to people or things, can't be acknowledged.

APPENDICE / APPENDIX / ANHANG / APPENDICE:

- I** ANODO ELETTRONICO (optional): Schema di collegamento
- ENG** ELECTRONIC ANODE: connection scheme
- DE** FREMDSTROM ANODE: Verbindungsschema
- FR** ANODE ELECTRONIQUE: Schéma de connexion

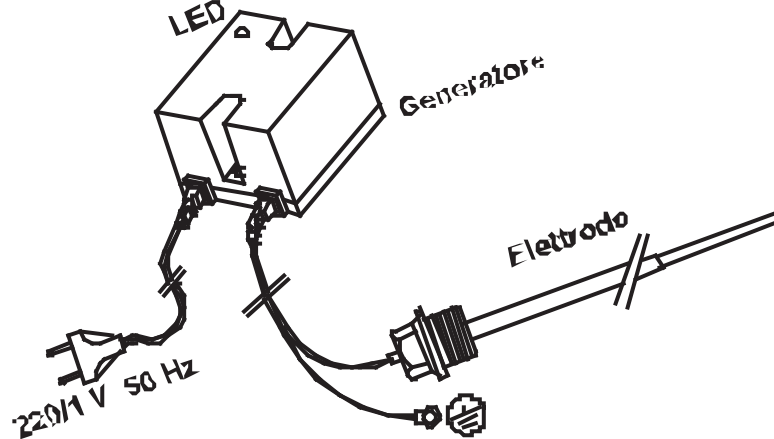

PARAMETRI DIRETTIVA 2009/125/CE , Reg. UE 2017-1369 - EN 12897
 DIRECTIVE PARAMETERS 2009/125/CE , Reg. UE 2017-1369 - EN 12897
 RICHTLINIE PARAMETER 2009/125/CE, Reg. UE 2017-1369 - EN 12897
 DIRECTIVE PARAMÈTRES 2009/125/CE, Reg. UE 2017-1369 - EN 12897

TAGLIA (ISOL.) SIZE (INSUL.) GRÖÖE (ISOL.) TAILLE (ISOL.)	CAPACITÀ CAPACITY KAPAZITÄT CAPACITÉ (L)	DISPERSIONE STANDING LOSS WÄRMEVERLUST PERTE DE CHALEUR (W)	DISP. SPEC. SPECIFIC LOSS SPEZIFISCHE VERLUST PERTE SPÉCIFIQUE (W/K)	CLASSE ENER. ENERGY CLASS ENERGIEKLASSE CLASSE ENERGIE
iXwater H-1 P 200-1 B (50 mm)	190	67	1,49	C
iXwater H-1 P 300-1 B (50 mm)	263	85	1,89	C
iXwater H-1 P 500-1 B (50 mm)	470	112	2,49	C
iXwater H-1 P 800-1 B (100 mm)	702	130	2,89	-

Архангельск (8182)63-90-72
 Астана (7172)727-132
 Астрахань (8512)99-46-04
 Барнаул (3852)73-04-60
 Белгород (4722)40-23-64
 Брянск (4832)59-03-52
 Владивосток (423)249-28-31
 Волгоград (844)278-03-48
 Вологда (8172)26-41-59
 Воронеж (473)204-51-73
 Екатеринбург (343)384-55-89
 Иваново (4932)77-34-06

Ижевск (3412)26-03-58
 Иркутск (395)279-98-46
 Казань (843)206-01-48
 Калининград (4012)72-03-81
 Калуга (4842)92-23-67
 Кемерово (3842)65-04-62
 Киров (8332)68-02-04
 Краснодар (861)203-40-90
 Красноярск (391)204-63-61
 Курск (4712)77-13-04
 Липецк (4742)52-20-81

Магнитогорск (3519)55-03-13
 Москва (495)268-04-70
 Мурманск (8152)59-64-93
 Набережные Челны (8552)20-53-41
 Нижний Новгород (831)429-08-12
 Новокузнецк (3843)20-46-81
 Новосибирск (383)227-86-73
 Омск (3812)21-46-40
 Орел (4862)44-53-42
 Оренбург (3532)37-68-04
 Пенза (8412)22-31-16

Пермь (342)205-81-47
 Ростов-на-Дону (863)308-18-15
 Рязань (4912)46-61-64
 Самара (846)206-03-16
 Санкт-Петербург (812)309-46-40
 Саратов (845)249-38-78
 Севастополь (8692)22-31-93
 Симферополь (3652)67-13-56
 Смоленск (4812)29-41-54
 Сочи (862)225-72-31
 Ставрополь (8652)20-65-13

Сургут (3462)77-98-35
 Тверь (4822)63-31-35
 Томск (3822)98-41-53
 Тула (4872)74-02-29
 Тюмень (3452)66-21-18
 Ульяновск (8422)24-23-59
 Уфа (347)229-48-12
 Хабаровск (4212)92-98-04
 Челябинск (351)202-03-61
 Череповец (8202)49-02-64
 Ярославль (4852)69-52-93

Киргизия (996)312-96-26-47

Россия (495)268-04-70

Казахстан (772)734-952-31